



## Do Epidurals Cause Autism? (No.) A Review of the Controversy and What Patients and Providers Need to Know

by Caroline Thomas, MD and Jennifer M. Banayan, MD

### BACKGROUND

Autism is a developmental disorder characterized by persistent deficits in communication and social interaction and is often associated with the presence of stereotypic or repetitive behaviors.<sup>1</sup> The incidence of autism in the United States is increasing and has prompted research directed at identifying risk factors for autism.<sup>2,3</sup>

The true etiology of autism is unknown. For 40 years, research has focused on perinatal and neonatal exposures and their relation to autism, and yet no definitive answers have been identified.<sup>4</sup> Obstetric and delivery factors in addition to neonatal exposures have been examined, and many of the results have been inconsistent.<sup>5</sup> Despite inconsistencies in the literature, most experts agree that the mechanism underlying the etiology of autism includes a combination of environmental and genetic risk factors.<sup>5</sup> On October 12, 2020, an article titled “Association between epidural analgesia

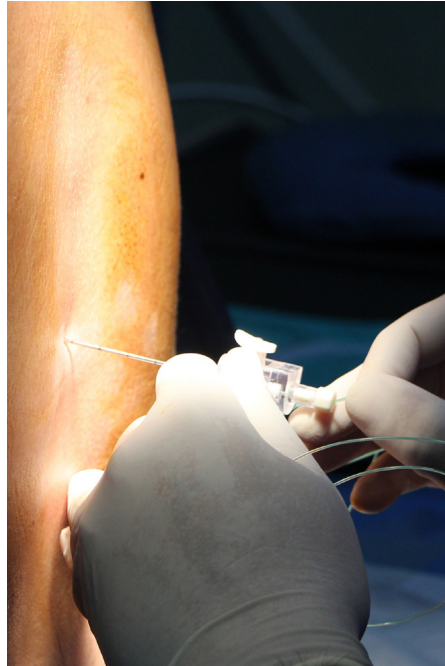

during labor and risk of autism spectrum disorders in offspring” was published in *JAMA Pediatrics*.<sup>6</sup> The article sparked debate and garnered multiple responses and critiques. This review will formally describe the existing literature on the potential for a correlation between epidurals and autism, provide a description of the controversy, and discuss important points for patients and providers to consider.

### THE JAMA PEDIATRICS ARTICLE

The authors’ objective was to assess whether lumbar epidural anesthesia (LEA) exposure was associated with an increased risk of developing autism in offspring. The study is a retrospective longitudinal cohort analysis of 147,895 singleton children born via vaginal delivery at 28–44 weeks gestational age in the Kaiser Permanente Southern California hospital system between Jan 1, 2008, and Dec 31, 2015.

See “Epidurals and Autism,” Page 3

## President’s Report: APSF: A Cause that Keeps Moving Forward

by Daniel J. Cole, MD

*Dan Cole, MD, has recently been elected as APSF President and has been a major contributor on the APSF Board of Directors for years. He has a long history of strong dedication to perioperative patient safety and is a pioneer in the field of brain health. Dan is a neuroanesthesiologist and professor of Clinical Anesthesiology in the Department of Anesthesiology and Perioperative Medicine at the David Geffen School of Medicine, University of California, Los Angeles. His leadership skills are incomparable, and he has held past positions as President of the American Society of Anesthesiologists and American Board of Anesthesiology. Please welcome him as we continue our quest that “no one shall be harmed by anesthesia care.”*

It is an honor to follow in the footsteps of legendary past APSF presidents such as Ellison Pierce, Robert Stoelting, and Mark Warner. It is a past that we can all be proud of; not only because of the scores of extraordinarily talented individuals who have been deeply committed to a vision “that no one shall be harmed by anes-

thesia care,” but also because APSF is an exceptional organization that has ensured that ideas became action, action that changed the world. Our organization has truly connected with our purpose and is one of the most amazing groups of people that I have been involved with.

Considering the complexity of health care systems, it should not be surprising that safety problems are endemic in health care. What is surprising is the sustained magnitude of the problem since the Institute of Medicine reported in 1999 (*To Err Is Human: Building a Safer Health System*) a headline that almost 100,000 deaths occur each year in hospitals due to medical error.<sup>1</sup>



Daniel J. Cole, MD, Current APSF President

See “President’s Report,” Page 6

### To Our APSF Readers:

If you are not on our mailing list, please subscribe at <https://www.apsf.org/subscribe> and the APSF will send you an email of the current issue.

## TABLE OF CONTENTS

### ARTICLES:

Do Epidurals Cause Autism? (No.) A Review of the Controversy and What Patients and Providers Need to Know ....Page 1  
 President's Report: APSF: A Cause that Keeps Moving Forward .....Page 1  
 APSF-Endorsed Statement on Revising Recommendations for Patient Monitoring During Anesthesia .....Page 7  
 Perioperative Management of Button Battery Ingestions in Children .....Page 9  
 What Role Can Professional Societies Play in Clinician Well-Being?  
 The American Society of Anesthesiologists' Experience .....Page 12  
 Unplanned Extubation in the Perioperative Environment .....Page 14  
 A Novel Approach for Improving COVID-19 Vaccine Rates: Administration During the Perioperative Period .....Page 17  
 A Practical Approach to Fostering Clinician Well-Being in an Academic Anesthesiology Department.....Page 24  
 APSF Awards 2022 Grant Recipients.....Page 26  
 Challenges and Solutions for Reducing Infection Risks When Accessing Vascular Catheters.....Page 30  
 Fostering a Learning Culture that Supports a Trainee's Wellness.....Page 35  
 Anesthetic Safety Considerations for Off-Site Cardiology Procedures.....Page 37  
 A Summary from the 2021 APSF Stoelting Conference: Clinician Safety: To Care is Human .....Page 41

### RAPID RESPONSE:

Thermal Injury After Use of a Convective Warming System .....Page 19  
 Response: Convective Warming Systems—Maintaining Normothermia in the Operating Room.....Page 21  
 Convection Warmers and Burn Injury—Still A Clear and Present Danger .....Page 23

### APSF ANNOUNCEMENTS:

Guide for Authors .....Page 2  
 Get Social With Us! .....Page 5  
 APSF Announces the Procedure for Submitting Grant Applications .....Page 5  
 APSF Newsletter Podcast Now Available Online @ APSF.org/podcast .....Page 11  
 APSF Stoelting Conference 2022: Save the Date—Crucial Patient Safety Issues in Office-Based and Non-Operating Room Anesthesia (NORA) .....Page 18  
 Crowdfunding .....Page 28  
 APSF Donor Page.....Page 29  
 Legacy Members .....Page 42  
 2022 Board Members and Committee Members:.....<https://www.apsf.org/about-apsf/board-committees/>

## Guide for Authors

A more detailed Guide to Authors with specific requirements for submissions can be found on line at <https://www.apsf.org/authorguide>

The APSF Newsletter is the official journal of the Anesthesia Patient Safety Foundation. It is widely distributed to a variety of anesthesia professionals, perioperative providers, key industry representatives, and risk managers. Therefore, we strongly encourage publication of those articles that emphasize and include the multidisciplinary, multiprofessional approach to patient safety. It is published three times a year (February, June, and October). **Deadlines for each issue are as follows: 1) February Issue: November 15th, 2) June Issue: March 15th, 3) October Issue: July 15th.** The content of the newsletter typically focuses on anesthesia-related perioperative patient safety. Decisions regarding content and acceptance of submissions for publication are the responsibility of the editors.

- All submissions should be submitted via Editorial Manager on the APSF website: <https://www.editorialmanager.com/apsf>
- Please include a title page which includes the submission's title, authors' full name, affiliations, conflicts of interest statement for each author, and 3–5 keywords suitable for indexing. Please include word count on the title page (not including references).
- Please include a summary of your submissions (3–5 sentences) which can be used on the APSF website to publicize your work.
- All submissions should be written in Microsoft Word in Times New Roman font, double-spaced, size 12.
- Please include page numbers on the manuscript.
- References should adhere to the American Medical Association citation style.
- References should be included as superscript numbers within the manuscript text.
- Please include in your title page if Endnote or another software tool for references is used in your submission.
- Authors must submit written permission from the copyright owner to use direct quotations, tables, figures, or illustrations that have appeared elsewhere, along with complete details about the source. Any permission fees that might be required by the copyright owner are the responsibility of the authors requesting use of the borrowed material, not the APSF. Unpublished figures require permission from the author.

Types of articles include (1) Invited review articles, Pro/Con Debates and Editorials, (2) Q and As, (3) Letters to the Editor, (4) Rapid Response, and (5) Conference reports.

- Review articles, invited Pro/Con debates, and Editorials are original manuscripts. They should focus on patient safety issues and have appropriate referencing. The articles should be limited to 2,000 words with no more than 25 references. Figures and/or tables are strongly encouraged.
- Q&A articles are submitted by readers regarding anesthesia patient safety questions to knowledgeable experts or designated consultants to provide a response. The articles should be limited to 750 words.
- Letters to the editor are welcome and should be limited to 500 words. Please include references when appropriate.
- Rapid Response** (to questions from readers), formerly known as, "Dear SIRS," which was the "Safety Information Response System," is a column that allows for expeditious communication of technology-related safety concerns raised by our readers, with input and response from manufacturers and industry representatives. Jeffrey Feldman, MD, current chair of the Committee on Technology, oversees the column and coordinates the readers' inquiries and the response from industry.

Commercial products are not advertised or endorsed by the APSF Newsletter; however, upon exclusive consideration from the editors, articles about certain novel and important safety-related technological advances may be published. The authors should have no commercial ties to, or financial interest in, the technology or commercial product.

If accepted for publication, copyright for the accepted article is transferred to the APSF. Permission to reproduce articles, figures, tables, or content from the APSF Newsletter must be obtained from the APSF.

**Individuals and/or entities interested in submitting material for publication should contact the Editors (Steven Greenberg, MD, and Jennifer Banayan, MD) directly at [greenberg@apsf.org](mailto:greenberg@apsf.org) or [banayan@apsf.org](mailto:banayan@apsf.org).**



The Official Journal of the  
Anesthesia Patient Safety Foundation

The **Anesthesia Patient Safety Foundation Newsletter** is the official publication of the nonprofit Anesthesia Patient Safety Foundation and is published three times per year in Wilmington, Delaware. Contributions to the Foundation are tax-deductible. ©Anesthesia Patient Safety Foundation, 2022.

The opinions expressed in this *Newsletter* are not necessarily those of the Anesthesia Patient Safety Foundation. The APSF neither writes nor promulgates standards, and the opinions expressed herein should not be construed to constitute practice standards or practice parameters. Validity of opinions presented, drug dosages, accuracy, and completeness of content are not guaranteed by the APSF.

### APSF Executive Committee 2021:

Daniel J. Cole, MD, President, Los Angeles, CA; Meghan Lane-Fall, MD, Vice President, Philadelphia, PA; Steven B. Greenberg, MD, Secretary, Chicago, IL; Douglas A. Bartlett, Treasurer, Boulder, CO; Lynn Reede, DNP, MBA, CRNA, FNAP, Director At-Large, Boston, MA.

### APSF Newsletter Editorial Board 2021:

Steven B. Greenberg, MD, Editor, Chicago, IL; Jennifer M. Banayan, MD, Editor, Chicago, IL; Edward A. Bittner, MD, PhD, Associate Editor, Boston, MA; Joshua Lea, CRNA, Assistant Editor, Boston, MA; Felipe Urdaneta, MD, Assistant Editor, Gainesville, FL; Aalok Agarwala, MD, MBA, Boston, MA; JW Beard, MD, Wilmette, IL; Heather Colombano, MD, Winston-Salem, NC; Jan Ehrenwerth, MD, New Haven, CT; John H. Eichhorn, MD, San Jose, CA; Meghan Lane-Fall, MD, Philadelphia, PA; Nikolaus Gravenstein, MD, Gainesville, FL; Bommy Hong Mershon, MD, Baltimore, MD; Tricia A. Meyer, PharmD, Temple, TX; Steven Shafer MD, Stanford, CA; Brian Thomas, JD, Kansas City, MO; Jeffrey S. Vender, MD, Winnetka, IL; Wilson Somerville, PhD, Editorial Assistant, Winston-Salem, NC. Please see the links of international editors at <https://www.apsf.org/wp-content/uploads/newsletter/APSF-International-Editors.pdf>

### Address all general, contributor, and subscription correspondence to:

Stacey Maxwell, Administrator  
Anesthesia Patient Safety Foundation  
P.O. Box 6668  
Rochester, MN 55903, U.S.A.  
[maxwell@apsf.org](mailto:maxwell@apsf.org)

Address *Newsletter* editorial comments, questions, letters, and suggestions to:

Steven B. Greenberg, MD  
Editor, APSF Newsletter  
[greenberg@apsf.org](mailto:greenberg@apsf.org)

Jennifer M. Banayan, MD  
Editor, APSF Newsletter  
[banayan@apsf.org](mailto:banayan@apsf.org)

Edward A. Bittner, MD, PhD  
Associate Editor, APSF Newsletter  
[bittner@apsf.org](mailto:bittner@apsf.org)

Assistant Editors:  
Josh Lea, CRNA  
Felipe Urdaneta, MD

### Send contributions to:

Anesthesia Patient Safety Foundation  
P.O. Box 6668  
Rochester, MN 55903, U.S.A.  
Or please donate online at [www.apsf.org](http://www.apsf.org).

# Five Medical Societies Provided Joint Statement That Epidural Analgesia is Safe and Effective for Labor Pain

From “Epidurals and Autism,” Page 1

Both anesthetic records and autism evaluations were readily available to researchers for review because the investigators had access to a systemwide electronic medical record system and a standardized method to evaluate children for autism at both 18 and 24 months.

In the *JAMA Pediatrics* study, the authors reported a 74.2% epidural usage rate, and they found that a significantly higher percentage (1.9%) of children in the LEA group received a diagnosis of autism spectrum disorder (ASD) versus 1.3% of children in the non-LEA group (HR 1.37, 95% CI 1.23–1.53). Of the children born to mothers in the LEA group, longer duration of exposure to LEA was associated with greater ASD risk (HR 1.05 per 4 hours of LEA exposure, 95% CI 1.01–1.09). In their discussion, the authors express concern regarding the safety and long-term health of offspring exposed to LEA and suggest further research is needed to identify the mechanism of the association between LEA and autism.<sup>6</sup>

### THE RESPONSE

Critics of the study expressed concerns over both methodology and the clinical implications of the study. On the same day the above article was published, five medical societies that represent more than 100,000 physicians including the American Society of Anesthesiologists, American College of Obstetricians and Gynecologists, Society for Obstetric Anesthesia and Perinatology, the Society for Pediatric Anesthesia, and the Society for Maternal-Fetal Medicine released a joint statement aimed to reassure pregnant women that neuraxial analgesia is safe, effective, and the “gold standard for labor pain relief.” The statement iterates that the study “does not provide credible scientific evidence that labor epidurals for pain relief cause autism” and cautions against implying causation from an observational study.<sup>7</sup> They reinforce the safety of epidurals based on the experience of millions of women each year and questioned the biological plausibility of the study given the low levels of drug exposure to the fetus in the setting of low-dose epidural local anesthetic and opiates used in common practice. They encouraged women to continue to utilize safe ways to relieve pain for a positive childbirth experience.

Several retrospective population-based studies from Canada and Denmark aimed at re-evaluating the association between epidurals and autism were published which contradicted the findings in the *JAMA Pediatrics* article

Table 1: Comparison of 2020–2021 Retrospective Analyses

	Qiu et al. <sup>6</sup>	Wall-Weiler et al. <sup>8</sup>	Mikkelsen et al. <sup>10</sup>	Hanley et al. <sup>9</sup>
<b>Study Design</b>	Retrospective longitudinal cohort	Longitudinal population-based cohort	Nationwide retrospective cohort	Longitudinal population-based cohort
<b>Publication Date</b>	October 2020	April 2021	September 2021	September 2021
<b>Study Population</b>	147,895 children born at Kaiser Southern California	123,175 children born in Manitoba, Canada	479,178 children born in Denmark	388,254 children born in British Columbia, Canada
<b>Exposure</b>	Maternal use and duration of epidural labor analgesia	Maternal use of epidural labor analgesia	Maternal use of epidural labor analgesia	Maternal use of epidural labor analgesia
<b>Neuraxial Rate</b>	74.2%	38.2%	19.4%	28.7%
<b>Outcome</b>	ASD associated with LEA. HR associated with LEA 1.37 (95% CI, 1.23–1.53)	ASD NOT associated with LEA. HR 1.08 (95% CI, 0.97–1.20)	ASD NOT associated with LEA. HR 1.05 (95% CI, 0.98–1.11)	Small association between ASD and LEA. HR 1.09 (1.00–1.15)
<b>Limitations</b>	<ul style="list-style-type: none"> <li>• Duration of LEA exposure instead of cumulative dose</li> <li>• Single center retrospective cohort</li> <li>• Baseline differences between patients receiving LEA vs not</li> <li>• Risk for residual confounding</li> </ul>	<ul style="list-style-type: none"> <li>• Less risk of residual confounding due to increased covariates included</li> <li>• No information regarding drug dosing</li> <li>• Baseline differences between patients receiving LEA vs not</li> <li>• Low epidural utilization</li> </ul>	<ul style="list-style-type: none"> <li>• Less risk of residual confounding due to increased covariates included</li> <li>• No information regarding drug dosing</li> <li>• Baseline differences between patients receiving LEA vs not</li> <li>• Low epidural utilization</li> </ul>	<ul style="list-style-type: none"> <li>• Baseline differences between patients receiving LEA vs not</li> <li>• Less risk of residual confounding due to increased covariates</li> <li>• No information regarding drug dosing</li> <li>• Low epidural utilization</li> </ul>

ASD: autism spectrum disorder, LEA: labor epidural analgesia, HR: hazard ratio, CI: confidence interval

(Table 1).<sup>8-10</sup> The follow-up studies increased the number of covariates in an attempt to minimize residual confounding, and some performed multiple sensitivity analyses to evaluate for potential bias. Of the three studies, two found no association between LEA and ASD.<sup>8,10</sup> One study from British Columbia, Canada, indicated a small, but statistically significant association between epidural analgesia and autism.<sup>11</sup> However, multiple sensitivity analyses within the study did not show an association, and based on their findings, the authors reported that given the high likelihood of residual confounding, the results do not provide sufficient evidence for an association.

Beyond medical societies, numerous individuals published critiques, criticisms, and letters to the editor with their own concerns related to the original article. The Editor in Chief of *JAMA Pediatrics* published an Editor’s Note in response to the article, noting that his “per-

sonal assessment is that the association is yet to be definitively established. If a more definitive study is done, *JAMA Pediatrics* will publish it.”<sup>12</sup> Many experts expressed concerns over residual and uncontrolled confounding in the original article.<sup>12-15</sup> For example, some responses suggested that the presence or absence of ASD in the parents should have been considered in the original study considering that ASD is estimated to be 40–80% genetically determined.<sup>16</sup> Others questioned the biological plausibility of how low-dose local anesthetic administered to the mother just a few hours before birth could lead to enough local anesthetic toxicity to permanently affect the developing brain.<sup>9,13-15</sup> There is very sparse data regarding any causal relationship between LEA and abnormal neurologic development in both humans and animals.<sup>17–20</sup>

See “Epidurals and Autism,” Next Page



## Labor Epidurals Offer Important Benefits To Parturients

From “Epidurals and Autism,” Preceding Page

Another interesting revelation is that studies attempting to identify a correlation between ASD and LEA all identified substantial baseline differences between women who do and do not receive epidural analgesia. Some of these confounding differences include maternal age, race, ethnicity, education level, household income, maternal diabetes, pre-eclampsia, and gestational age.<sup>21</sup> These differences suggest that women receiving epidural analgesia may be inherently different than those who did not. As it is difficult to account for global aspects of maternal health such as general mental state, nutrition, self-care/prenatal care, residual confounding may remain in not only the original article, but in the subsequent retrospective studies as well.<sup>21</sup>

LEA offers a number of important benefits to women during labor. Neuraxial analgesia provides superior pain management as compared to IV analgesia or nitrous oxide.<sup>22</sup> The presence of an epidural catheter *in situ* acts as a safety mechanism for women requiring urgent or emergent cesarean delivery by potentially preventing the increased risks associated with general anesthesia, improves post-partum pain scores, and allows maternal participation in bonding immediately after cesarean delivery.<sup>22,23</sup> Consequently, one of the most serious concerns with the *JAMA Pediatrics* study is the inference of a causal relationship between LEA and ASD leading to significant maternal anxiety and guilt over choosing LEA for labor pain relief. This could lead to a reduction in LEA usage, which has the potential to increase rates of general anesthesia for emergent cesarean delivery, which in turn may increase neonatal exposure to maternal medications and increase maternal morbidity.<sup>15,16,22-25</sup> The authors of the *JAMA Pediatrics* article suggested that their findings indicate the importance of future research to “better understand the neurodevelopmental safety of LEA to our children.”<sup>26</sup>

Although it is clearly stated in the discussion of the *JAMA Pediatrics* article that there is no causal relationship between LEA and autism, it is difficult to glean this point from the title and abstract of the article.<sup>6</sup> Noncausal associations can sometimes be misinterpreted by the general public, and inaccurate representation of data in the media is common. One example of this is the assumption that vaccines cause autism, a concern that initiated from a single, subsequently retracted, study from the *Lancet* in 1998 that has subsequently led to widespread vaccine hesitancy, which the WHO has labelled one of the top 10 threats to global



health.<sup>27,28</sup> Great care should be taken when discussing risks and benefits of epidurals with patients to dispel inaccuracies and emphasize the safety of epidurals.

In conclusion, no subsequent publication has found conclusive evidence of an association or correlation between LEA and ASD, despite more rigorous methodology. When discussing risks and benefits with our patients, care should be taken to reinforce the safety profile of LEA. While concerns regarding the association between ASD and LEA by patients should not be dismissed, the current literature supports neither a correlation nor a causative relationship between the two, and that fact should be firmly reiterated to all our patients.

*Caroline Thomas, MD, is an obstetric anesthesiology fellow at Northwestern University Feinberg School of Medicine.*

*Jennifer Banayan, MD, is an associate professor of anesthesiology at Northwestern University Feinberg School of Medicine. She is also editor of the APSF Newsletter.*

*The authors have no conflicts of interest.*

### REFERENCES

1. American Psychiatric Association. Diagnostic and statistical manual of mental disorders. Published online 2013. <https://www.ncbi.nlm.nih.gov/nlmcatalog/101604226>
2. Myers SM, Voigt RG, Colligan RC, et al. Autism spectrum disorder: incidence and time trends over two decades in a population-based birth cohort. *J Autism Dev Disord*. 2019;49:1455-1474. doi.org/10.1007/s10803-018-3834-0
3. Maenner MJ, Shaw KA, Baio J, et al. Prevalence of autism spectrum disorder among children aged 8 years — Autism and Developmental Disabilities Monitoring Network, 11 Sites, United States, 2016. *Mmwr Surveill Summ*. 2020;69:1-12.
4. Glasson EJ, Bower C, Petterson B, et al. Perinatal factors and the development of autism: a population study. *Arch Gen Psychiatr*. 2004;61:618-627. doi.org/10.1001/arch-psyc.61.6.618
5. Gardener H, Spiegelman D, Buka SL. Perinatal and neonatal risk factors for autism: a comprehensive meta-analysis. *Pediatrics*. 2011;128:344-355. doi.org/10.1542/peds.2010-1036
6. Qiu C, Lin JC, Shi JM, et al. Association between epidural analgesia during labor and risk of autism spectrum disorders in offspring. *Jama Pediatr*. 2020;174:1168-1175. doi.org/10.1001/jamapediatrics.2020.3231
7. Joint statement of the Society for Obstetric Anesthesia and Perinatology, the American Society of Anesthesiologists, the Society of Pediatric Anesthesia, the American College of Obstetricians and Gynecologists, and the Society for Maternal-Fetal Medicine. Labor epidurals do not cause autism; safe for mothers and infants, say anesthesiology, obstetrics, and pediatric medical societies. Published online October 12, 2020. [https://soap.memberclicks.net/assets/docs/JAMAPeds\\_Epidurals\\_SOAP\\_ASA\\_SPA\\_ACOG\\_SMFM\\_Media\\_Response\\_101220%20%281%29.pdf](https://soap.memberclicks.net/assets/docs/JAMAPeds_Epidurals_SOAP_ASA_SPA_ACOG_SMFM_Media_Response_101220%20%281%29.pdf)
8. Wall-Wieler E, Bateman BT, Hanlon-Deaman A, et al. Association of epidural labor analgesia with offspring risk of autism spectrum disorders. *Jama Pediatr*. 2021;175:698-705. doi.org/10.1001/jamapediatrics.2021.0376
9. Hanley GE, Ip A, Oberlander TF. Epidural analgesia and autism spectrum disorder risk—the challenges inherent in complex observational research. *Jama Pediatr*. 2021;175:675-677. doi.org/10.1001/jamapediatrics.2021.0382
10. Mikkelsen AP, Greiber IK, Scheller NM, Lidegaard Ø. Association of labor epidural analgesia with autism spectrum disorder in children. *JAMA*. 2021;326:1170-1177. doi.org/10.1001/jama.2021.12655
11. Hanley GE, Bickford C, Ip A, et al. Association of epidural analgesia during labor and delivery with autism spectrum disorder in offspring. *JAMA*. 2021;326:1178-1185. doi.org/10.1001/jama.2021.14986
12. Christakis DA. More on epidurals and autism. *JAMA Pediatr*. 2021;175:705-705. <https://doi.org/10.1001/jamapediatrics.2021.0385>
13. Carrier FM, Lavoie A, Zaphiratos V. Epidural analgesia during labour and autism risk: getting lost on the causal path. *Can J Anaesth*. 2021;68:277-284. doi.org/10.1007/s12630-020-01880-5
14. Glezeron BA, Trivedi V, Mclsaac DI. On the stated association between labour epidural analgesia and risk of autism

See “Epidurals and Autism,” Next Page

## No Conclusive Association Found Between Autism and Labor Epidural Use

### From "Epidurals and Autism," Preceding Page

- spectrum disorder in offspring. *Can J Anaesth*. 2021;68:428–429. doi.org/10.1007/s12630-020-01869-0
15. Kern-Goldberger AR, Burris HH, Levine LD. Methodologic concerns with concluding a link between epidural and autism spectrum disorder. *JAMA Pediatr*. 2021;175:536–537. doi.org/10.1001/jamapediatrics.2020.6692
  16. Saito M, Nakamura K, Hirota K. Concerns for labor analgesia and autism spectrum disorders. *J Anesth*. 2021;35:319–320. doi.org/10.1007/s00540-020-02880-x
  17. Decocq G, Brazier M, Hary L, et al. Serum bupivacaine concentrations and transplacental transfer following repeated epidural administrations in term parturients during labour. *Fundam Clin Pharm*. 1997;11:365–370. doi.org/10.1111/j.1472-8206.1997.tb00850.x
  18. Sakuma S, Oka T, Okuno A, et al. Placental transfer of lidocaine and elimination from newborns following obstetrical epidural and pudendal anesthesia. *Pediatr Pharmacol (New York)*. 1985;5:107–115.
  19. Demeulemeester V, Hauthem HV, Cools F, Lefevere J. Transplacental lidocaine intoxication. *J Neonatal Perinatal Med*. 2018;(Preprint):1–3. doi.org/10.3233/npm-1791
  20. Cabrera OH, Gulvezan T, Symmes B, et al. Sex differences in neurodevelopmental abnormalities caused by early-life anaesthesia exposure: a narrative review. *Brit J Anaesth*. 2020;124:e81–e91. doi.org/10.1016/j.bja.2019.12.032
  21. Wong CA, Stevens H. Labor epidural analgesia and autism spectrum disorder. *JAMA*. 2021;326:1155–1157. doi.org/10.1001/jama.2021.15369
  22. Lim G, Facco FL, Nathan N, Waters JH, Wong CA, Eltzschig HK. A review of the impact of obstetric anesthesia on maternal and neonatal outcomes. *Anesthesiology*. 2018;129:192–215. doi.org/10.1097/aln.0000000000002182
  23. McQuaid E, Leffert LR, Bateman BT. The role of the anesthesiologist in preventing severe maternal morbidity and mortality. *Clin Obstet Gynecol*. 2018;61:372–386. doi.org/10.1097/grf.0000000000000350
  24. Palanisamy A. Maternal anesthesia and fetal neurodevelopment. *Int J Obstet Anesth*. 2012;21:152–162. doi.org/10.1016/j.ijoa.2012.01.005
  25. Chien LN, Lin HC, Shao YHJ, et al. Risk of autism associated with general anesthesia during cesarean delivery: a population-based birth-cohort analysis. *J Autism Dev Disord*. 2015;45:932–942. doi.org/10.1007/s10803-014-2247-y
  26. Qiu C, Desai V, Xiang AH. Methodologic concerns with concluding a link between epidural and autism spectrum disorder—reply. *JAMA Pediatr*. 2021;175:537–538. doi.org/10.1001/jamapediatrics.2020.6695
  27. Geoghegan S, O'Callaghan KP, Offit PA. Vaccine safety: myths and misinformation. *Front Microbiol*. 2020;11:372. doi.org/10.3389/fmicb.2020.00372
  28. Godlee F, Smith J, Marcovitch H. Wakefield's article linking MMR vaccine and autism was fraudulent. *Brit Med J*. 2011;342:c7452. doi.org/10.1136/bmj.c7452

## Get Social With Us!



The APSF is eager to connect with patient safety enthusiasts across the internet on our social media platforms. Over the past year, we have made a concerted effort to grow our audience and identify the best content for our community. We've seen increases in followers and engagement by several thousand percent, and we hope to see that trajectory continue into 2022. Please follow us on Facebook at <https://www.facebook.com/APSForg/> and on Twitter at <https://twitter.com/APSForg>. Also, connect with us on LinkedIn at <https://www.linkedin.com/company/anesthesia-patient-safety-foundation-apsf>. We want to hear from you, so please tag us to share your patient safety related work, including your academic articles and presentations. We'll share those highlights with our community. If you are interested in joining our efforts to amplify the reach of APSF across the internet by becoming an Ambassador, please reach out via email to Marjorie Stiegler, MD, our Director of Digital Strategy and Social Media at [stiegler@apsf.org](mailto:stiegler@apsf.org), Emily Methangkool, MD, the APSF Ambassador Program Director at [methangkool@apsf.org](mailto:methangkool@apsf.org), or Amy Pearson, Social Media Manager at [pearson@apsf.org](mailto:pearson@apsf.org). We look forward to seeing you online!



Marjorie Stiegler, MD, APSF Director of Digital Strategy and Social Media.



## ANNOUNCES THE PROCEDURE FOR SUBMITTING APSF GRANT APPLICATIONS

**FEBRUARY 18, 2022, IS THE DEADLINE TO SUBMIT LETTERS OF INTENT (LOIs) FOR AN APSF GRANT TO BEGIN JANUARY 1, 2023**

- LOIs will be accepted electronically beginning January 7, 2022, at: [apsf.org/apply](https://www.apsf.org/apply)
- The maximum award is \$150,000 for a study conducted over a maximum of two years to begin **January 1, 2023.**
- Based on the APSFs Scientific Evaluation Committee's review of these LOIs, a limited number of applicants will be invited to submit a full proposal.

Instructions for submitting a Letter of Intent can be found at:

<https://www.apsf.org/grants-and-awards/investigator-initiated-research-iir-grants/>

- Annual deadlines for future years will be published at [www.apsf.org](http://www.apsf.org).

# President's Report

From "President's Report," Page 1

To quote the World Health Organization, "The occurrence of adverse events due to unsafe care is likely one of the ten leading causes of death and disability in the world."<sup>2</sup> Patient safety is a "global health priority" and our work is far from done.

Safety is the foundation upon which the pillars by which we achieve quality care and the essential trust of our patients are built. These pillars include system competency, clinical competency of the provider(s), teamwork and communication, primacy of the patient's interest, and the well-being of the workforce caring for patients.

In the above cited report, the Institute of Medicine stated that "anesthesia mortality rates are about one death per 200,000–300,000 anesthetics administered, compared with two deaths per 10,000 anesthetics in the early 1980s."<sup>1</sup> Although the exact figure of anesthesia-related mortality is controversial, there is no doubt that our specialty has made remarkable gains in safety over the past decades. Accordingly, as a specialty, we have not left the space that we worked so hard in during the 80s and 90s, but have expanded our vision of safety from reducing mortality with a focus on drug errors and hypoxia due to a difficult airway, to improving perioperative processes that enhance the long-term functional, cognitive, and psychological health of our patients.

We have a proud past, but an even more exciting future. Founding APSF President Ellison "Jeep" Pierce focused on the premise that safety is not a one and you're done process. It is a long game that must be sustained by research, education, and by embedding science and best practices into the systems of care within which we work. It is analogous to running a marathon without a finish line. It is a one-step-at-a-time commitment to a shared struggle. It is about the end of a beginning stage of work and the beginning of a new stage of improvement. And finally, it is about the rewards from working at the frontier of quality and safety, knowing that you made the world a better place.

It seems as though more change has occurred in health care over the last few years than in the previous 30 years, and, like it or not, the next decade promises a tsunami of change. For example, multidisciplinary care pathways that incorporate precision medicine and are designed to improve patient outcomes by integrating preoperative risk assessment, prehabilitation, standardized intra- and postoperative

management, and home rehabilitation will continue to grow and become commonplace. Home rehabilitation is likely to incorporate microsensors, remote monitoring, and the "hospital at home" model of care. Other technological advances include automated systems of anesthesia delivery, machine learning, artificial intelligence, and telehealth. We will have to learn about and carefully analyze these disruptive innovations to ensure that safety is not compromised and that safety standards are proactively embedded into new processes of patient care.

The APSF has at least six levers by which we turn ideas into action and action into results. They include research, education, the *Newsletter*, other communication vehicles (e.g., social media), collaboration with other stakeholders in patient safety, and advocacy. We will continue to pull these levers to make progress in the fight against preventable harm. Our focus this year will be directed at our ten priorities (<https://www.apsf.org/patient-safety-priorities>).

We have a deeply committed group of volunteers, who, I am confident, will rise to the safety challenges that will result from disruptive innovation that will occur in the perioperative space over the next decade. We rely on your financial support to achieve our goals, and we will use

our resources wisely to ensure that anesthesiology continues to be a leader in patient safety. Sometimes it is best to resist change, sometimes to align with change, but we at the APSF will be proactive to continue our work to fulfill the vision "that no one shall be harmed by anesthesia care." It is indeed a sacred trust that we have with our patients and our goal is to further the foundation of trust on which our specialty has been built.

*Dan Cole, MD, is professor of clinical anesthesiology in the Department of Anesthesiology and Perioperative Medicine David Geffen School of Medicine, University of California at Los Angeles. He is also the current president of the Anesthesia Patient Safety Foundation.*

*The author has no conflicts of interest.*

## REFERENCES:

1. Kohn LT, Corrigan JM, Donaldson MS, Editors; Committee on Quality of Health Care in America, Institute of Medicine. 2000. *To Err Is Human: Building a Safer Health System*. Washington, DC: The National Academies Press. <https://doi.org/10.17226/9728>. Accessed December 6, 2021.
2. World Health Organization. Patient Safety. <https://www.who.int/news-room/fact-sheets/detail/patient-safety>. Published 2019. Updated September 13, 2019. Accessed December 6, 2021.

## Ten Priorities of Safety

1. Culture of Safety
2. Teamwork
3. Clinical Deterioration
4. Non-Operating Room Anesthesia (the subject of our 2022 Stoelting Conference, <https://www.apsf.org/event/apsf-stoelting-conference-2022>)
5. Perioperative Brain Health
6. Opioid-Related Harm
7. Medication Safety
8. Infectious Diseases
9. Clinician Safety (the subject of our 2021 Stoelting Conference)
10. Airway Management



# APSF-Endorsed Statement on Revising Recommendations for Patient Monitoring During Anesthesia

by The APSF Committee on Technology

This Statement was authored by the APSF Committee on Technology and approved by the APSF Board of Directors.

The APSF Committee on Technology (COT) has reviewed statements\* for patient monitoring during anesthesia care published by a sampling of professional organizations from around the world. Since patient safety during anesthesia is independent of location, the Committee believes that the inconsistencies identified between the various statements should be addressed and appropriate revisions encouraged. Specifically, there are gaps between the various statements that have significant patient safety implications.<sup>1,2</sup> The following recommendations for patient monitoring have been reviewed and approved by the APSF Board of Directors.

The primary goal of this statement is to identify monitoring practices that are not part of existing statements by some professional organizations, but are believed to enhance patient safety. A secondary goal is to foster efforts by professional organizations to harmonize guidelines across all anesthesia professional organizations so that every anesthetized patient can benefit from best monitoring practices.

This statement is not intended to set a monitoring standard. It is based primarily upon expert consensus. The role of expert consensus to setting guidelines that support and enhance clinical practices has been underscored in a recent publication and editorial.<sup>3,4</sup> Indeed, the first standards adopted for patient monitoring were based upon expert consensus and persist to the present day with well accepted impact on reducing anesthesia-related mortality.<sup>5</sup> Furthermore, APSF recognizes that the desired approach to monitoring will ultimately be dictated by available resources and resource-limited locations simply may not be able to comply with these recommendations. However, this statement hopefully will help anesthesia professionals advocate for resources to comply with these recommendations when the resources are available.

## BACKGROUND

Patient safety during general anesthesia requires maintaining organ perfusion and oxygenation. Achieving this goal requires that hemodynamics, ventilation, and oxygenation be monitored, and for the most part, existing monitoring statements from all of the professional organizations reviewed by the APSF-COT address this monitoring need.

Ensuring patient safety, however, also requires drug-induced unconsciousness and often, immobility. Delivering the appropriate drug dosage to induce unconsciousness appropriate to the clinical goals is essential for safe care. Drug underdosing can lead to awareness, or allow the patient to move during a critical part of the surgical procedure. Drug overdosing can cause undesired physiologic changes (eg. hypotension) or postoperative

residual drug effects (e.g., residual neuromuscular blockade). Statements that address the importance of monitoring drug effectiveness or undesired residual effect are the most glaring gaps between statements by different professional societies. In what follows, the APSF-COT briefly reviews each of these patient safety threats and makes recommendations to promote revision of existing statements.

## Specific Recommendations to Enhance Existing Monitoring Statements to Improve Patient Safety

### I. AWARENESS PREVENTION—INHALED ANESTHESIA

**Patient safety threat:** Patients expect to be unconscious during general anesthesia. Awareness and memory of intraoperative events carries significant and well documented patient morbidity.

The use of potent inhaled anesthetics at 0.7 MAC, or greater, is our single best line of defense against awareness in the patient who has been given a neuromuscular blocking agent. This has been well documented.<sup>6-11</sup> Because the International Organization for Standardization (ISO) already requires that anesthesia workstations configured to deliver inhaled agents measure the end-expired concentration of the inhaled anesthetic, the incorporation of this requirement into a revised standard ought to be straightforward and inexpensive, address a major patient safety issue,

and help to harmonize with international monitoring standards.

In some patients, it is not possible to maintain an inhaled anesthetic concentration consistent with 0.7 MAC due to hemodynamic compromise, and in those patients, monitoring for the risk of awareness is especially compelling. In those cases, an EEG-based monitor of anesthetic depth should be used to help ensure adequate depth of anesthesia.

#### PROPOSED MONITORING PRACTICE:

- **Whenever an inhaled agent is administered, its end-expired concentration shall be measured and a low concentration alarm be activated if available.**
- **Whenever a neuromuscular blocking agent is administered during inhalational anesthesia, if 0.7 MAC cannot be maintained, an EEG-based monitor of anesthetic depth**

**should be used and an inadequate anesthetic depth alarm limit set if available.**

- **Exceptions would include procedures (e.g., Neurosurgery) where the technology for EEG-based monitoring cannot be placed or used effectively.**

### II. AWARENESS PREVENTION – INTRAVENOUS ANESTHESIA

**Patient safety threat:** In the patient given a neuromuscular blocking agent, intra-operative awareness has been reported to occur. Indeed, the risk is greater when intravenous agents (most often propofol) rather than inhaled agents are used as the primary anesthetic. Underdosing can be due to technical error or to the inherent pharmacokinetic and pharmacodynamic variability of the drug (and drug combinations) in the population, combined with the inability to continuously and routinely measure drug concentration(s).

\*Statements can be guidelines, standards or recommendations depending upon the organization issuing the statement.

## Specific Monitoring Recommendations to Improve Patient Safety

From “Monitoring for Safety,” Preceding Page

An EEG-based monitor of unconsciousness (depth of anesthesia monitor) is required to reduce the likelihood of awareness whenever total intravenous anesthesia is combined with the administration of neuromuscular blocking agents. Anesthetic depth monitors based upon processed EEG analysis are currently the most readily available and well studied devices for assessing intravenous anesthetic effect and the potential for awareness. Various parameters are extracted from the EEG including spectral edge calculation, density and compressed spectral array displays and derived indices like the bispectral and patient state indices. Requiring an EEG-based monitor to provide insight into intravenous drug effect addresses a major patient safety issue, and helps to harmonize international monitoring standards.

### PROPOSED MONITORING PRACTICE:

- Whenever a neuromuscular blocking agent is administered during total intravenous anesthesia, an EEG-based monitor of drug effect is recommended and alarm limits activated when available.
- Exceptions would include procedures (e.g., Neurosurgery) where the technology for EEG-based monitoring cannot be placed or used effectively.

### III. POSTOPERATIVE RESIDUAL MUSCLE WEAKNESS

**Patient safety threat:** Neuromuscular blocking agents exhibit pronounced pharmacokinetic and pharmacodynamic variability. Consequently, whenever neuromuscular blocking agents have been administered, some residual neuromuscular block may be present at the end of the procedure, compromising patient safety (e.g., airway obstruction, aspiration). Quantitative neuromuscular blockade monitoring has well documented advantages over qualitative or subjective monitoring and is the preferred method. APSF believes that any type of neuromuscular blockade monitoring enhances patient safety compared with no monitoring at all when a neuromuscular blocking agent is used.

### PROPOSED MONITORING PRACTICE:

Whenever a neuromuscular blocking agent is administered, a neuromuscular block monitor shall be applied and used. Quantitative is preferable to qualitative neuromuscular blockade monitoring.

### IV. AIRWAY PRESSURE MONITORING

**Patient safety threat:** Excessive airway pressure may cause lung barotrauma. Protective

lung ventilation has gained considerable attention as a means to minimize lung trauma. Monitoring airway pressure is not consistently recommended by all professional societies. Manufacturing standards require airway pressure monitoring be present in ventilating devices, so it is not a major change for the device manufacturers and consumers to comply with this recommendation. APSF advocates for including it in the statements for patient monitoring for completeness, and to enhance awareness of this important parameter.

### PROPOSED MONITORING PRACTICE:

When ventilation is controlled by a mechanical ventilator, there shall be in continuous use a device that is capable of measuring airway pressure. Alarms for detecting disconnection of components of the breathing system and dangerously high pressure shall be available and enabled. The device must give an audible signal when its alarm threshold is exceeded.

### REFERENCES

1. Hendrickx JFA. Anesthetic monitoring recommendations: How consistent are they across the globe? *APSF Newsletter*. 2019;34:34–36. <https://www.apsf.org/article/anesthetic-monitoring-recommendations-how-consistent-are-they-across-the-globe/>. Accessed on December 27, 2021.
2. Hendrickx JFA, Feldman J, Schueler HU. Anesthetic monitoring recommendations during general anesthesia: How consistent are they across the globe? In: ESA Patient Safety and Quality Committee. Ten years of the “Helsinki Declaration on Patient Safety in Anesthesiology”—An expert opinion on various perioperative safety aspects. *European Journal of Anaesthesiology*. 2020;37:521–610.
3. Laserna A, Rubinger DA, Barahona-Correa JE, et al. Levels of evidence supporting the North American and European perioperative care guidelines for anesthesiologists between 2010 and 2020: a systematic review. *Anesthesiology*. 2021;135:31–53.
4. Neuman MD, Apfelbaum JL. Clinical practice guidelines in anesthesiology: adjusting our expectations. *Anesthesiology*. 2021;133:9.
5. Cullen D, Cooper J, Eichhorn J, et al. Expanding on the origins, evolution, and spread of anesthesia monitoring standards. *Anesth Analg*. 2021;133:e14–e15.
6. Sani O, Shafer SL. MAC attack? *Anesthesiology*. 2003;99:1249–1250.
7. Dilger JP. From individual to population: the minimum alveolar concentration curve. *Curr Opin Anaesthesiol*. 2006;19:390–396.
8. Katoh T, Ikeda K. The effects of fentanyl on sevoflurane requirements for loss of consciousness and skin incision. *Anesthesiology*. 1998;88:18–24.
9. Sonner JM. Issues in the design and interpretation of minimum alveolar anesthetic concentration (MAC) studies. *Anesth Analg*. 2002;95:609–614.
10. Chortkoff BS, Gonsowski CT, Bennett HL, et al. Subanesthetic concentrations of desflurane and propofol suppress recall of emotionally charged information. *Anesth Analg*. 1995;81:728–736.
11. Eger EI II, Sonner JM. How likely is awareness during anesthesia? *Anesth Analg*. 2005;100:1544 [letter].

### APPENDIX:

#### Selected Standards of Professional Societies Reviewed for this Statement

Standards for basic anesthetic monitoring. Committee of Origin: Standards and Practice Parameters. Approved by the ASA House of Delegates on October 21, 1986, last amended on October 20, 2010, and last affirmed on October 28, 2015.

American Association of Nurse Anesthetists (AANA). Standards for Nurse Anesthesia Practice. (2019) Standard 9, Monitoring and Alarms. [https://www.aana.com/docs/default-source/practice-aana-com-web-documents-all/professional-practice-manual/standards-for-nurse-anesthesia-practice.pdf?sfvrsn=e00049b1\\_20](https://www.aana.com/docs/default-source/practice-aana-com-web-documents-all/professional-practice-manual/standards-for-nurse-anesthesia-practice.pdf?sfvrsn=e00049b1_20).

Checketts MR, Alladi R, Ferguson K, et al., Association of Anaesthetists of Great Britain and Ireland. Recommendations for standards of monitoring during anaesthesia and recovery 2015. *Anaesthesia*. 2016;71:85–93.

European Board of Anaesthesiology (EBA) recommendations for minimal monitoring during anaesthesia and recovery. UEMS Anesthesiology Section, European Board of Anaesthesiology (EBA). <http://www.eba-uems.eu/resources/PDFS/safety-guidelines/EBA-Minimal-monitor.pdf>

Guidelines on monitoring in anaesthesia. Version 5, May 2017. Document No. HKCA– P1 – v5. Prepared by College Guidelines Committee. Endorsed by HKCA council. Next Review Date 2022. <https://www.hkca.edu.hk/wp-content/uploads/2020/12/Resources-college-guideline-P1.pdf>

Australia and New Zealand College of Anaesthetists (ANZCA), Recommendations on monitoring during anaesthesia. PS 18, 2013. [https://www.anzca.edu.au/getattachment/0c2d9717-fa82-4507-a3d6-3533d8fa844d/PG18\(A\)-Guideline-on-monitoring-during-anaesthesia.pdf](https://www.anzca.edu.au/getattachment/0c2d9717-fa82-4507-a3d6-3533d8fa844d/PG18(A)-Guideline-on-monitoring-during-anaesthesia.pdf)

Standards of practice and graduate competencies, International Federation of Nurse Anesthetists (2016). <https://ifna.site/ifna-standards-of-education-practice-and-monitoring>

Gelb AW, Morriss WW, Johnson W, et al. International standards for a safe practice of anaesthesia workgroup. World Health Organization-World Federation of Societies of Anaesthesiologists (WHO-WFSA) International Standards for a Safe Practice of Anesthesia. *Can J Anaesth*. 2018;65:698–708.

ISO standard 80601-2-13:2011 AMD 1 2015 AMD 2 2018; Medical electrical equipment — Part 2-13: Particular requirements for basic safety and essential performance of an anaesthetic workstation.



# Perioperative Management of Button Battery Ingestions in Children

by Monica Hoagland, MD; Sydney Yee, MD; Richard Ing, MBBCh, FCA (SA); and Debnath Chatterjee, MD, FAAP

Foreign body ingestions are common events among pediatric patients. Button battery ingestions are particularly dangerous. Although the incidence of button battery ingestions has not changed over the last 30 years,<sup>1</sup> the rates of emergency department visits, major morbidity, and mortality have risen dramatically since the introduction of the 3-volt–20 mm lithium batteries in 2006.<sup>1,3</sup> These batteries are larger and more powerful than their predecessors, which has increased the incidence of esophageal impaction and significant tissue injury.<sup>2</sup> The overall incidence of major morbidity or mortality after button battery ingestion is 0.42%.<sup>1</sup> However, in children under six years old who ingest batteries >20 mm, the rates of major complications are as high as 12.6%.<sup>2</sup> All reported fatalities have occurred in children under five years old.<sup>4</sup>

The primary mechanism of injury is the generation of electrolytic current that hydrolyzes tissue fluids and produces hydroxide ions at the battery’s negative pole.<sup>2</sup> This creates a highly alkaline environment that raises the local tissue pH up to 12 or 13, leading to liquefactive necrosis of adjacent tissues. They may also cause perforation and erosion into adjacent structures, including the airway, vasculature, mediastinal structures, or spinal cord. Most of the 67 fatalities reported to the National Capital Poison Center are due to hemorrhage from esophageal-vascular fistulae or complications of tracheoesophageal fistulae.<sup>4</sup> The development of an aorto-esophageal fistula is an ominous finding, as there are only four reported cases of survival in the literature.<sup>5-8</sup>

Given the potential for significant morbidity and mortality, it is imperative to rapidly triage and manage patients who present with a confirmed or suspected button battery ingestion. Perioperative management guidelines, risk factors for significant injury, and new preoperative mitigation strategies are of particular importance for anesthesia professionals. The damage caused by button batteries is determined by the location and duration of impaction, as well as the orientation, size, and voltage



of the button battery.<sup>9,10</sup> Esophageal battery impactions prolong contact between the battery and esophageal tissue, increasing the risk of damage. Tissue damage begins to develop within 15 minutes of contact with a button battery, and the risk of severe injury increases with the duration of button battery exposure.<sup>11</sup> Compromised tissues may continue to have progressive liquefactive necrosis for days to weeks after button battery removal.<sup>12</sup> Due to these issues, the button battery must be removed via endoscopy emergently, preferably within 2 hours of ingestion, and the patient must be monitored postoperatively for signs of progressive injury.<sup>12</sup>

Unfortunately, foreign body ingestions in children are frequently unwitnessed, and the symptoms may easily be incorrectly attributed to respiratory or gastrointestinal illnesses, which significantly delays diagnosis.<sup>13</sup> Therefore, a high index of clinical suspicion is necessary. In addition, many parents and health care providers are unaware of the dangers of button battery ingestion and may not seek emergency treatment.<sup>14</sup> Even if the patient is promptly brought for medical care, the medical facility may not have the pediatric specialists and equipment required to manage the patient, including emergency physicians, otolaryngologists, gastroenterologists, general or cardiothoracic surgeons, and anesthesia professionals. If

transfer to another facility is required, the battery removal will be further delayed.

Standardized protocols for the triage and management of patients with suspected button battery ingestion have been published by multiple groups.<sup>9,10,15,16</sup> The goal of these guidelines is to identify high-risk patients and streamline the process of removing the button battery. Comprehensive management guidelines from the National Capital Poison Center can be found at [www.poisson.org/battery/guideline](http://www.poisson.org/battery/guideline). The initial evaluation should include x-rays of the neck, chest, and abdomen to locate and identify the ingested object. Any foreign body impacted in the esophagus, symptomatic gastric button batteries, and batteries that are co-ingested with a magnet must be immediately removed. A conservative management approach may be taken if the child is >12 years old, asymptomatic, with no history of esophageal pathology, and with a known ingestion of a single battery < 12 mm diameter without other foreign bodies.

Once the decision is made to proceed with removal, a risk assessment must be performed (Table 1). Esophageal impactions are most likely to occur in young children (<5 years old), patients with underlying esophageal pathology or stricture, and after ingestion of larger batteries (>20 mm diameter). In addition, impaction at the level of the aortic arch, particularly with the negative pole (narrow side) of the battery facing posteriorly, increases the risk of vascular injury. Any sign of gastrointestinal bleeding is ominous and signals a potential vascular-esophageal fistula. Patients meeting any of these criteria are considered high risk. Those with an esophageal impaction not meeting the above criteria or a symptomatic gastric battery are deemed intermediate risk. Finally, asymptomatic patients and/or ingestion of small gastric batteries (<20 mm) in older children (>5 years old) with no history of esophageal pathology are low risk.<sup>9</sup>

See “Button Batteries,” Next Page

**Table 1: Risk Stratification for Button Battery Ingestions in Children<sup>9</sup>**

High Risk	Intermediate Risk	Low Risk
<ul style="list-style-type: none"> <li>• Children &lt;5 years old</li> <li>• Battery &gt;20-mm diameter</li> <li>• Underlying esophageal pathology or stricture</li> <li>• Esophageal impaction                             <ul style="list-style-type: none"> <li>– at the level of the aortic arch</li> <li>– with the negative pole (narrow side) facing posteriorly</li> <li>– prolonged impaction</li> </ul> </li> <li>• Signs of gastrointestinal bleeding</li> </ul>	<ul style="list-style-type: none"> <li>• Esophageal impaction not meeting high-risk criteria</li> <li>• Symptomatic gastric button batteries</li> </ul>	<ul style="list-style-type: none"> <li>• Children &gt;5 years old</li> <li>• Battery &lt;20-mm diameter</li> <li>• No history of esophageal pathology or stricture</li> <li>• Asymptomatic gastric button batteries</li> </ul>

# Goal is to Remove Battery Within 2 Hours of Ingestion

## From “Button Batteries,” Preceding Page

Intermediate- and low-risk patients may be cared for in a general operating room by gastroenterologists with or without general surgeons on standby. For patients at high risk, consideration should be given to involving interventional cardiologists or cardiothoracic surgeons. They may require more invasive vascular access, hemodynamic monitoring, volume resuscitation, and blood product administration.

Detailed discussions of the anesthetic management and postoperative monitoring required for these patients have been described in other publications.<sup>9,10</sup> The airway should be secured by rapid sequence induction. The team must be prepared for hemodynamic and/or respiratory instability around the time of battery removal, particularly if the battery has caused vascular or airway injury. After battery removal, a repeat endoscopy and bronchoscopy are performed to assess the esophagus and airway for injury.

Postoperatively, the patient must be monitored for progressive injury to the esophagus and surrounding tissues. The duration and acuity level of inpatient care depends on the initial injury seen during battery removal. Repeated

anesthetics may be required for serial imaging studies and/or endoscopic evaluation.

Due to the potential for delayed button battery removal and ongoing tissue damage, several mitigation strategies have been investigated. Button batteries create an alkaline environment that ultimately leads to mucosal damage and liquefactive necrosis.<sup>12,17</sup> Studies in cadaveric and live piglet models have demonstrated that irrigation with weakly acidic solutions prior to battery removal neutralizes the alkaline environment and decreases tissue damage compared to irrigation with saline.<sup>17,18</sup> These solutions include common household beverages (juice, soda, and sports drinks) as well as viscous solutions (honey and syrup), which are safe for a child to ingest. Honey and sucralfate most effectively neutralize the alkaline environment created by the button battery. They are also associated with less extensive tissue damage and decreased rates of delayed esophageal perforation compared to saline irrigation.<sup>18</sup> Both solutions are weakly acidic and form a viscous physical barrier between the battery and the tissue. In a separate study, irrigation with 0.25% acetic acid solution after button battery removal neutralized the pH of the esophageal tissue, which may also

decrease the progression of tissue injury and delayed complications seen after button battery removal.<sup>17</sup>

Based on these studies, the management guidelines from the National Capital Poison Control Center now include recommendations to mitigate tissue injury prior to and after button battery removal.<sup>15</sup> Honey and/or sucralfate should be administered orally (10 mL every 10 minutes) from the time of ingestion until button battery removal. Due to concerns for botulism in infants, patients <12 months old should not be given honey. Nothing should be administered orally if it has been >12 hours since battery ingestion or if there are concerns for esophageal perforation, mediastinitis, or sepsis. No other medications, fluids, or foods should be administered orally, and vomiting should not be induced as the dislodged battery may be aspirated and vomiting may cause or worsen esophageal perforation.

It is critical to note that while these interventions mitigate injury, the battery must still be emergently removed. Parents must proceed to the emergency department immediately, and removal must not be delayed due to the

See “Button Batteries,” Next Page

**1a**

## BUTTON BATTERIES CAN BE DEADLY

### WHAT IS A BUTTON BATTERY?

They are small, round, metallic batteries found in many common electronic devices.

### WHY ARE THEY DANGEROUS?

They are small and shiny which increases the risk of being accidentally swallowed by children.

They can burn through a child's throat in just **2 hours** and cause bleeding, serious complications, and even **death**.

### HOW CAN I AVOID ACCIDENTS?

Keep new and spent batteries out of reach of small children.

Do not store batteries with medications or food.

Safely throw out used batteries.

Secure and tighten all battery compartments.

### IF YOUR CHILD SWALLOWS A BUTTON BATTERY:

Call the hotline: **1-800-498-8666**.

Seek **immediate medical care** at the closest hospital.

**Do not** induce vomiting, or give any food or drinks except honey.

If your child is over one year old, give 2 teaspoons of honey, every 10 minutes, up to six times, to coat the battery. Do not delay medical care to get honey.

Scan or Click Yee ST, Hoagland MA, Ing RJ, Chatterjee D. Department of Anesthesiology, Children's Hospital Colorado, Aurora, CO.

SPONSORED BY:

**1b**

## BUTTON BATTERY INGESTIONS

### FOR THE ANESTHESIA PROVIDER

#### The Problem

>3,500 injections annually

12.6% of children <6 years old develop serious or fatal injuries.

#### The Mechanism

A button battery in the esophagus generates an electric current causing caustic injury and tissue necrosis.

Damage depends on duration of impaction, location, size, and voltage.

Death is most commonly due to hemorrhage from an aortoesophageal fistula.

#### High-Risk Patients

- Age < 5 years
- Battery ≥20 mm
- Prior bleed
- Negative pole or narrow side facing posteriorly
- Impacted at the level of the aorta

#### Anesthetic Considerations

**Extraction is urgent.** Do not wait for symptoms. Goal is removal within 2 hours.

**Do not delay** for NPO time. Patients may have received honey or sucralfate to minimize tissue damage.

Consider appropriate staff, equipment, and location for battery removal.

Assess risk factors for bleeding. Prepare for instability and blood loss.

Patient may require inpatient monitoring and repeat procedures.

Scan or Click Yee ST, Hoagland MA, Ing RJ, Chatterjee D. Department of Anesthesiology, Children's Hospital Colorado, Aurora, CO.

SPONSORED BY:

Figure 1: Infographics describing the management of button battery ingestions for both parents (1a) and anesthesia providers (1b). Used with permission obtained by authors.

## Dangers of Button Battery Ingestion Are Under-Appreciated by Parents and Medical Providers

### From “Button Batteries,” Preceding Page

patient’s oral intake. After the battery is removed and there is no evidence of perforation, the esophagus may be irrigated with 0.25% acetic acid solution (50–150mL) to neutralize residual alkaline substances.

In conclusion, the dangers of button battery ingestions and the need for emergent battery removal are underappreciated by many parents and medical providers. Further, many clinicians are unaware of the current recommendations for mitigation strategies, and anesthesia professionals may inappropriately delay cases for patients who have recently ingested honey or sucralfate.<sup>14</sup> Our group at Children’s Hospital Colorado created infographics for both parents (Image 1a) and anesthesia professionals (Image 1b) to address these issues. It is our hope that these infographics can be displayed in a variety of settings, such as in medical offices, on medical websites geared toward parents, and in medical journals, to help increase awareness of these recommendations. These infographics can be accessed on the Society for Pediatric Anesthesia website ([www.pedsanesthesia.org](http://www.pedsanesthesia.org)). Although primary prevention of ingestion is the ultimate management goal, it is also important to publicize treatment guidelines to help decrease the serious and potentially fatal outcomes seen after button battery ingestions.

Monica Hoagland, MD, is an associate professor of anesthesiology at Children’s Hospital

Colorado, University of Colorado School of Medicine, Aurora, CO.

Sydney Lee, MD, is a pediatric anesthesiology fellow at Children’s Hospital Colorado, University of Colorado School of Medicine, Aurora, CO.

Richard Ing, MBBCh, FCA (SA), is a professor of anesthesiology at Children’s Hospital Colorado, University of Colorado School of Medicine, Aurora, CO.

Debnath Chatterjee, MD, FAAP, is an associate professor of anesthesiology at Children’s Hospital Colorado, University of Colorado School of Medicine, Aurora, CO.

The authors have no conflicts of interest.

### REFERENCES

1. National Capital Poison Center. Button battery ingestion statistics. Available at: <https://poison.org/battery/stats>. Accessed July 12, 2021
2. Litovitz T, Whitaker N, Clark L, et al. Emerging battery-ingestion hazard: clinical implications. *Pediatrics*. 2010;125:1168–1177.
3. Sharpe SJ, Rochette LM, Smith GA. Pediatric battery-related emergency department visits in the United States, 1990–2009. *Pediatrics*. 2012;129:1111–1117.
4. National Capital Poison Center. Fatal button battery ingestions: 67 reported cases. Available at: <https://poison.org/battery/fatalcases>. Accessed July 12, 2021.
5. Spiers A, Jamil S, Whan E, et al. Survival of patient after aorto-oesophageal fistula following button battery ingestion. *ANZ J Surg*. 2012;82:186–187.
6. Mahajan S, Jaswal V, Thingnam SKS, Dogra N. Successful surgical management of an aorto-oesophageal fistula caused by button battery ingestion. *Eur J Cardiothorac Surg*. 2019;55:790–791.
7. Wakimoto M, Willer BL, McKee C, et al. Successful management of an aorto-esophageal fistula following button battery ingestion: a case report and review of the literature. *Saudi J Anaesth*. 2021;15:193–198.
8. Sinclair EM, Stevens JP, McElhanon B, et al. Development and repair of aorto-esophageal fistula following esophageal button battery impaction: a case report. *J Pediatr Surg Case Rep*. 2021;66.
9. Hoagland MA, Ing RJ, Jatana KR, et al. Anesthetic implications of the new guidelines for button battery ingestion in children. *Anesth Analg*. 2020;130:665–672.
10. Eck JB, Ames WA. Anesthetic implications of button battery ingestion in children. *Anesthesiology*. 2020;132:917–924.
11. Tanaka J, Yamashita M, Yamashita M, Kajigaya H. Esophageal electrochemical burns due to button type lithium batteries in dogs. *Vet Hum Toxicol*. 1998;40:193–196.
12. Jatana KR, Litovitz T, Reilly JS, et al. Pediatric button battery injuries: 2013 task force update. *Int J Pediatr Otorhinolaryngol*. 2013;77:1392–1399.
13. Buttazzoni E, Gregori D, Paoli B, et al. Symptoms associated with button batteries injuries in children: an epidemiological review. *Int J Pediatr Otorhinolaryngol*. 2015;79:2200–2207.
14. Cairns R, Brown JA, Lachireddy K, et al. Button battery exposures in Australian children: a prospective observational study highlighting the role of poisons information centres. *Clin Toxicol*. (Phila). 2019;57:404–410.
15. National Capital Poison Center button battery ingestion triage and treatment guidelines. <https://poison.org/battery/guideline>. Accessed July 12, 2021.
16. Sethia R, Gibbs H, Jacobs IN, et al. Current management of button battery injuries. *Laryngoscope Investig Otolaryngol*. 2021;6:549–563.
17. Jatana KR, Rhoades K, Milkovich S, Jacobs IN. Basic mechanism of button battery ingestion injuries and novel mitigation strategies after diagnosis and removal. *Laryngoscope*. 2017;127:1276–1282.
18. Anfang RR, Jatana KR, Linn RL, Rhoades K, Fry J, Jacobs IN. pH-neutralizing esophageal irrigations as a novel mitigation strategy for button battery injury. *Laryngoscope*. 2019;129:49–57.



## APSF Newsletter Podcast

Now Available Online @ [APSF.org/podcast](https://www.apsf.org/podcast)



The APSF now offers you the opportunity to learn about anesthesia patient safety on the go with the Anesthesia Patient Safety Podcast. The weekly APSF podcast is intended for anyone with an interest in perioperative patient safety. Tune in to learn more about recent *APSF Newsletter* articles with exclusive contributions from the authors and episodes focused on answering questions from our readers related to patient safety concerns, medical devices, and technology. In addition, special shows that highlight important COVID-19 information on airway management, ventilators, personal protective equipment, drug information, and elective surgery recommendations are available. The mission of the APSF includes being a leading voice for anesthesia patient safety around the world. You can find additional information in the show notes that accompany each episode at [APSF.org](https://www.apsf.org). If you have suggestions for future episodes, please email us at [podcast@apsf.org](mailto:podcast@apsf.org). You can also find the Anesthesia Patient Safety Podcast on Apple Podcasts or Spotify or anywhere that you listen to podcasts. Visit us at [APSF.org/podcast](https://www.apsf.org/podcast) and at @APSForg on Twitter, Facebook, and Instagram.



Allison Bechtel, MD  
APSF Podcast Director



# What Role Can Professional Societies Play in Clinician Well-Being? The American Society of Anesthesiologists' Experience

by Amy E. Vinson, MD, FAAP

*The information provided is for safety-related educational purposes only, and does not constitute medical or legal advice. Individual or group responses are only commentary, provided for purposes of education or discussion, and are neither statements of advice nor the opinions of APSF. It is not the intention of APSF to provide specific medical or legal advice or to endorse any specific views or recommendations in response to the inquiries posted. In no event shall APSF be responsible or liable, directly or indirectly, for any damage or loss caused or alleged to be caused by or in connection with the reliance on any such information.*

Clinician well-being has come to the forefront of discussions of not only health care worker satisfaction, but also sustainability of the health care industry. These discussions are occurring at every level, from the work of the National Academy of Medicine's Action Collaborative on Clinician Well-Being and Resilience to sessions at society meetings, hospital well-being committees, lay press, and social media. What has become clearer with every dataset published is that systems-based solutions ought to be the focus for the clinician burnout and disengagement crisis we are currently in.<sup>1</sup> With the impending worsening of workforce shortages anticipated within the coming years, this will be increasingly more important.<sup>2</sup> Accordingly, many national organizations, including professional societies, have been collaborating for several years now to meet the challenge head-on and answer the question: What role can professional societies play in clinician well-being?

At the 2021 APSF Stoelting Conference, I had the opportunity to present the experience of the American Society of Anesthesiologists (ASA) and how we are approaching clinician well-being. The Committee on Physician Well-Being (COPWB) was established in 2019 just prior to the COVID-19 pandemic, but this came after years of engagement from a large number of anesthesiologists interested in various aspects of well-being. When the committee formed, in an effort to maintain the engagement of as many interested people as possible, four working groups were established to conduct the work of the committee: The Working Group on Systems & Policy That Impact Well-Being, Working Group on Education & Endeavors, Working Group on Clinician Mental Health & Suicide Prevention, and the Working Group on ASA Outreach. While Committee membership is by application only, any ASA member may participate in the Working Groups. We also made the decision to make the [ASA Well-Being webpage](#) publicly facing since many of the challenges faced are not unique to physicians and resources often serve all members of the health care team. The COPWB also endorsed a survey study to assess the state of burnout in U.S. attending anesthesiologists, focusing on potentially actionable demographic and practice-based factors. This survey study was

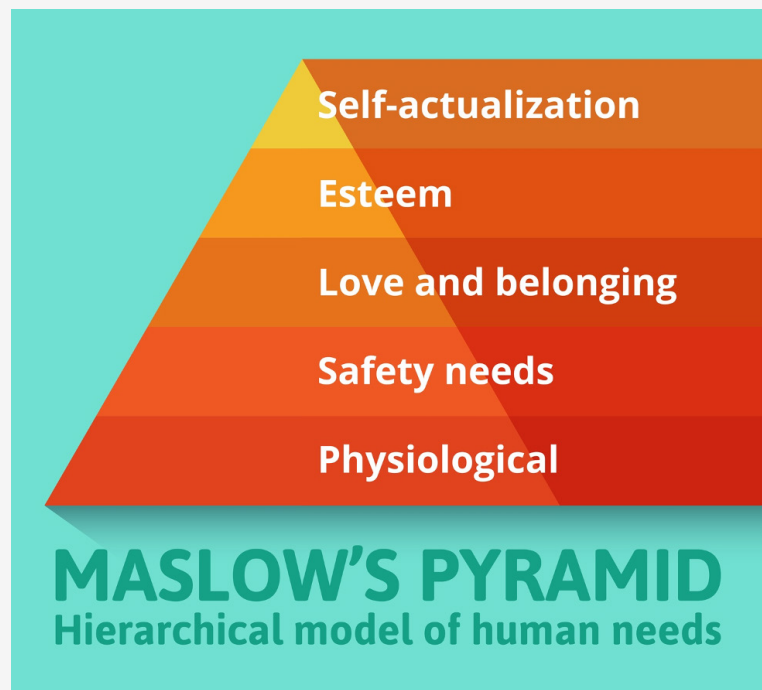

Figure 1: Maslow's Hierarchical Model of Human Needs.

scheduled to be distributed during the first week of March 2020.

Recently, this study of burnout in anesthesiologists was published with nearly 4,000 respondents.<sup>3</sup> Using the Maslach Burnout Inventory, which assesses occupational burnout across the three domains of emotional exhaustion, depersonalization, and a low sense of personal accomplishment, the authors assessed both high risk for burnout (reaching threshold levels of emotional exhaustion or depersonalization), and burnout syndrome (simultaneously reaching threshold levels of emotional exhaustion, depersonalization and a low sense of personal accomplishment). The findings, representing the state of affairs prior to the peak of the COVID-19 pandemic (survey responses mostly from the first half of March, 2020), demonstrated 59% of US attending anesthesiologists were at high risk for burnout and nearly 14% had the burnout syndrome. While the incidence data are important, the associations between burnout and various demographic and practice-based factors is also informative. Primarily, the response to the ques-

tion, "How supported do you feel in your work-life?" was significantly associated with burnout. If one espoused little to no support in their work-life, they had an adjusted odds ratio of 6.7 for being at high risk for burnout and an odds ratio of 10 for burnout syndrome. This information has bolstered the COPWB's commitment to focus on an end-goal of promoting a culture of well-being and support within our workplaces, as described below.

The working groups had just begun to tackle their respective agendas when the COVID-19 pandemic hit in full force; it became quickly apparent that the pandemic-associated experiences, stressors, and imbalances were very heterogeneous and many people raised concerns about the experiences of women and others underrepresented in medicine (e.g., racial and ethnic minority individuals). In response to this, the ASA established an ad hoc Committee on Systemic Life Imbalances, charged with assessing the unequal burdens shouldered by many within our ranks and how groups and departments could address those differential challenges.

See "Professional Societies," Next Page

## On Creating A Culture of Well-Being For Health Care Professionals

### From “Professional Societies,” Preceding Page

As discussions began, it was immediately evident that not only were these imbalances entrenched long before COVID-19, but they represented a challenge that only sweeping organizational culture change could adequately address.

One of the first work-products from the Committee on Physician Well-being was a brief “one-pager” resource on “Creating a Culture of Well-being for Healthcare Workers,” which can be downloaded from the [ASA Well-being website](#). This document approaches workplace culture by addressing the need to satisfy higher levels of Maslow’s Hierarchy of needs (Figure 1), starting with our most basic survival needs, then rising to the higher-level needs attached to a sense of meaning and purpose. The approach is structured not by the outdated and traditional “command and control” rubric of organizational leadership, but instead by robust and open two-way communication, free from fear of retribution, and reinforced by accountability and enhanced communication from leadership. Such a workplace culture would foster collaboration among all stakeholders within the organization, ultimately building stronger, more inclusive teams.

This “one-pager” served as a rational starting point for addressing the diversity of needs within our anesthesia workforce. In a joint statement between the ad hoc Committee on Systemic Life Imbalances and the Committee on Physician Well-being, the “ASA Statement on Creating Cultures of Well-being for Healthcare Workers” was proposed as a resolution and approved by the ASA House of Delegates at the 2021 ASA Annual Meeting in October. This statement advocates for a five-point approach to transforming work culture and is supported by four well-sourced documents providing more granular and pragmatic detail to the recommendations.

The approach is somewhat intuitive in terms of its approach to a balanced work and home life, but also considers pandemic-specific interruptions to various career trajectories. Many of these may seem particularly daunting given current staffing shortages, but nonetheless represent recommended goals as rebuilding occurs. The recommendations are as follows (where italicized, amended to be inclusive of all health care workers) and are available at <https://www.asahq.org/standards-and-guidelines/asa-statement-on-creating-a-culture-of-well-being-for-health-care-workers> :

Our intention is for these recommendations to serve as a framework for workplace improvements, ultimately leading to an improved culture of support for our broader workforce. The challenges faced by anesthesiologists are not unique to them, and we encourage all professional societies to develop and adopt similar strategies if they have not already done so. Collaborations among professional societies, representing varying perspectives, can only serve to strengthen our collective response to health care worker needs.

To say that the COVID-19 pandemic shifted the ways in which we think about many aspects of life would be an understatement. Many of the things we felt we had to do a certain way were simply done a different way for over a year. While disruptive, this also established a creative mindset. Coupled with a broad openness to discussing aspects of work-life integration, mental health, and well-being, this creative mindset represents an opportunity to transform work culture in a way not previously believed feasible. Put simply—the cracks have been revealed—we can choose to pave over and ignore the faults in our system, or we can work to repair them and build back stronger than ever imagined.

*Amy E. Vinson, MD, FAAP, is an assistant professor of Anaesthesia, Harvard Medical School, senior associate in Perioperative Anesthesiology, Boston Children’s Hospital, director of Clinician Well-Being, Department of Anesthesiology, Critical Care & Pain Medicine, and chair, American Society of Anesthesiologists Committee on Physician Well-Being.*

*The author has no conflicts of interest.*

### REFERENCES

1. National Academy of Medicine, National Academies of Sciences, Engineering and Medicine. Taking action against clinician burnout: a systems approach to professional well-being. The National Academies Press; 2019. [doi.org/10.17726/25521](https://doi.org/10.17726/25521)
2. Oslock WM, Satiani B, Way DP, et al. A contemporary reassessment of the US surgical workforce through 2050 predicts continued shortages and increased productivity demands. *Am J Surg.* 2021;223:28–35. Published online 2021. [doi.org/10.1016/j.amjsurg.2021.07.033](https://doi.org/10.1016/j.amjsurg.2021.07.033)
3. Afonso AM, Cadwell JB, Staffa SJ, Zurakowski D, Vinson AE. Burnout rate and risk factors among anesthesiologists in the United States. *Anesthesiology.* 2021;134:683–696. [doi.org/10.1097/aln.0000000000003722](https://doi.org/10.1097/aln.0000000000003722)

### Recommendations for a Culture of Well-Being

1. **Destigmatization of Mental Health Care:** “We should advocate for a culture of openness, normalization, and destigmatizing of mental health in health care workers. Health care workers should be able to seek care through mental health resources without fear of impact on licensure or credentialing.”
2. **Flexibility in Scheduling:** “Institutions/departments/health care systems/groups should seek to accommodate flexible work schedules.”
3. **Care-giving Support:** “Institutions/health care systems/departments/groups should seek to provide childcare/family care resource options and support.”
4. **Accommodation for Career Interruptions:** “Institutional/departmental/health care systems/group accommodations should be made for loss of academic productivity due to increased or new clinical duties, loss of academic time, loss of progress in promotion or partnership, changes in clinical roles, and increased caregiving demands.”
5. **Well-being Initiatives:** “General wellness initiatives should be deployed, including but not limited to well-being education, peer support, substance use disorder prevention and treatment, suicide prevention training, and diversity, equity, and inclusion initiatives.”

# Unplanned Extubation in the Perioperative Environment

by Lauren Berkow, MD, FASA, and Arthur Kanowitz, MD, FACEP

## INTRODUCTION

In most cases, extubation is a planned, intentional, and controlled procedure that occurs in the operating room, the Intensive Care Unit (ICU), or the emergency department. However, even when the extubation is planned, intentional, and controlled, the rate of complications related to extubation in the operating room setting has been reported to be around 12%.<sup>1,2</sup> Unplanned extubation (UE) is any extubation that is not planned, intentional, and controlled.<sup>3,4</sup> This complication can occur in the ICU or in the operating room setting, resulting in significant morbidity and mortality.<sup>3,7</sup> Unplanned extubation can occur when the patient dislodges or removes the endotracheal tube by pulling on it (self-extubation), or if an external force is applied to the endotracheal tube during movement of the patient or other nursing care (accidental extubation). It can also occur in any location where an intubated patient may receive care, such as the operating room, the ICU, the emergency department, procedural areas, or during patient transport. While many publications in the literature exist that address the challenges of difficult intubation, the complications and challenges of extubation have been less widely studied. This complication is not often tracked as a quality measure, so its incidence is most likely under-reported. This article discusses the scope of the problem and provides potential strategies to reduce the risk and incidence of UE.

## INCIDENCE AND RISK FACTORS

The incidence of unplanned extubation as reported in the literature varies widely from a median of 7.3% (0.5–35.8%) in adults to as high as 18.2% (1–80.8%) in the neonatal population.<sup>5–8</sup> The majority of studies were conducted in the ICU, and the reported incidence of UE in the operating room remains unknown. In the neonatal ICU, unplanned extubation is the fourth most commonly reported adverse event.<sup>5</sup> A recent retrospective study found a higher incidence of unplanned extubation in COVID-19 patients (13.2%) compared to the incidence in intubated patients not infected with COVID-19 (4.3%).<sup>9</sup>

## UNPLANNED EXTUBATION IN THE OPERATING ROOM

Unplanned extubation is uncommon in the operating room since patients receive general anesthesia, as well as muscle relaxation, but it can still occur. Self-extubation can occur during emergence, and usually does not require re-intubation, but can pose a risk of vocal cord injury if the ETT cuff is still inflated. More serious

**Table 1: Risk Factors for Unplanned Extubation<sup>12-14</sup>**

Movement of the patient
Manipulation of the endotracheal tube
Inadequate sedation
Inadequate securement of the endotracheal tube
Lack of physical restraints
Restlessness or agitation
Delirium or confusion
Prone positioning (during surgical procedures and management of COVID-19 patients or patients with ARDS)
Absence of clear policies and procedures related to weaning
Lack of or unclear plan for extubation
Lack of adequate staffing

is accidental extubation during the surgical procedure, which can occur during positioning, during prone surgical procedures or during head or neck procedures, which are in proximity to the airway. Several case reports exist of accidental extubation during prone spine surgery.<sup>10-11</sup> Other procedures performed with the patient positioned 180 degrees away from the anesthesia machine restrict the anesthesia professional's ability to visualize and monitor the endotracheal tube, which can potentially result in delayed recognition of tube dislodgement or extubation during the procedure. UE can also occur during the transfer of intubated patients (to or from the OR table, or from the OR to the ICU).

## UNPLANNED EXTUBATION IN THE ICU

Unplanned extubation is more common in the ICU environment compared to the operating room setting, where muscle relaxation is less often employed, the patient to provider ratio is typically higher, and changes in position or tube manipulation are more frequent (Table 1). Self-extubation is the most common cause of UE in adult ICU patients, but other causes, classified as accidental extubation, include patient movement during bedside procedures, extubation during transport (between departments in the hospital or interfacility transports), and airway suctioning maneuvers.<sup>12</sup> Intubated patients with COVID-19 often require prone placement to optimize ventilation, which is a known risk factor for UE.<sup>9</sup>

## COMPLICATIONS RELATED TO UNPLANNED EXTUBATION

Airway-related complications during emergence and extubation in the operating room have been reported to be as high as 30%.<sup>15</sup> Airway-related complications are even higher outside the operating room and in uncontrolled situations.<sup>16</sup> Unplanned extubation can result in immediate complications such as injury to the vocal cords or trachea, hypoxemia, hemodynamic instability, respiratory failure, brain damage, cardiac arrest, and death.<sup>15,17</sup> If re-intubation is required after UE, the presence of hemodynamic instability or airway edema can make airway management more difficult. If the UE occurs during the surgical procedure, immediate access to the patient's airway may be inhibited due to surgical drapes or positioning, making airway management challenging. This may result in delays in providing oxygenation and ventilation to patients. The incidence of re-intubation after unplanned extubation varies in the literature, but has been reported to be as high as 89%, and may carry a poor prognosis.<sup>18,19</sup> The majority of studies looking at the need for re-intubation after unplanned extubation have been performed in the ICU setting, and reintubation is more commonly required after accidental extubation than self-extubation.<sup>19</sup> Unplanned extubation has also been associated with a statistically significant increased risk of ventilator-associated pneumonia (increased from 13.8% to 30%), and prolonged ICU and hospital length of stay.<sup>19</sup>

## COST BURDEN

The complications of unplanned extubation and the impact on length of stay result in a significant cost burden. Studies that have factored in the cost of ICU care and the costs of complications due to unplanned extubation estimate that the overall yearly cost burden in the United States is approximately five billion dollars annually.<sup>20,21</sup> A single unplanned extubation adds \$41,000 to the average cost of an ICU stay (the average ICU stay costs \$59,000) and increases total ICU stay costs to an estimated \$100,178.<sup>21</sup>

## UNPLANNED EXTUBATION PREVENTION

Is this complication preventable? Several strategies can be employed to reduce the risk of UE. The most important first step is recognition of the problem based upon data. Accurate tracking of every extubation and classification of every extubation as planned versus unplanned, using predefined definitions of

See "Unplanned Extubation," Next Page



# Communication With the Perioperative Team is Critical To Reduce Unplanned Extubations

From “Unplanned Extubation,” Preceding Page  
 extubation, are needed to identify if a problem exists (Table 2). Since UE is often not tracked, and most electronic medical record systems do not include data sets that track accidental or self-extubation, it is often not acknowledged as a problem. Another important step is recognition of risk factors. Education about how to identify and mitigate risk factors for UE should be provided to all clinicians that manage intubated patients. Vats et al. created an airway risk assessment scoring tool for pediatric patients to identify patients at higher risk.<sup>22</sup> Incorporating risk assessment and mitigation strategies for UE into protocols used by providers managing these patients can increase awareness and potentially reduce complications.<sup>22,23</sup>

In the operating room, briefings and timeouts can identify cases at higher risk for unplanned extubation, similar to discussions around cases at risk for airway fire. Many cases at risk for airway fire are also at higher risk for accidental extubation. These types of cases often require sharing of the airway and positioning of the patient far away from the anesthesia professional, and sometimes require extubation and re-intubation during a procedure. A pre-induction discussion of the optimal method to secure the endotracheal tube, how the tube may be manipulated during the procedure, and the location and availability of airway equipment in case of the need for urgent re-intubation should be performed to mitigate risk of UE.

Protocols for bedside tube manipulation and patient transfers, bedside reminders with visual cues, and standardization of tube securement methods have been demonstrated to be effective in mitigating UE.<sup>23</sup> Optimizing securement of the endotracheal tube may also reduce risk. Although no single securement method for the endotracheal tube has been proven to be superior, several attributes have been suggested in the literature (Table 3) and by the Patient Safety Movement Foundation in their Patient Safety Solutions (Table 4).<sup>24</sup> Good communication and teamwork, especially during high-risk procedures such as suctioning, turning, or transport of a patient have been shown to be beneficial in reducing UE events.<sup>23</sup> It is recommended that at least one provider be responsible for protecting the tube during these procedures to prevent dislodgement.<sup>23</sup>

Strategies to maximize oxygenation and ventilation after both planned and unplanned extubation can be employed to avoid the need for intervention both in the operating room and in

**Table 2: Extubation Classification Tool**

Source: Unplanned Extubation Actionable Patient Safety Solutions (APSS) [patientsafetymovement.org](http://patientsafetymovement.org)  
 Accessed on November 15, 2021. Reprinted with permission.

Extubation Classification		Endotracheal Tube (ETT) removed by:	When ETT was removed:		
			Was readiness for safe removal of ETT determined? <small>Assessment for Liberation Potential and Successful Strategic Wean completed?</small>	Was removal of ETT intentional? <small>Airway provider made a conscious decision to remove the ETT as evidenced by a written/verbal order to extubate</small>	Was removal of ETT controlled? <small>Patient was prepped and balloon was deflated prior to extubation</small>
Planned Extubation		Provider	Yes	Intentional	Controlled
Unplanned Extubation	Self-Extubation	Patient/Unknown	No/Yes	Unintentional	Uncontrolled
Unplanned Extubation	Accidental Extubation	Provider	No/Yes	Unintentional	Uncontrolled
Unplanned Extubation	Device Malfunction/Obstruction	Provider	No	Intentional	Controlled
Unplanned Extubation	Presumed Internal Dislodgement	Provider	No	Intentional	Controlled

**Table 3: Suggested Characteristics of an Optimal Endotracheal Tube Securement Device**

Provides good stabilization against external forces that may dislodge tube
Prevents tube movement that can cause malpositioning
Prevents tube movements that can lead to fluid getting past the balloon
Facilitates suctioning without dislodgement
Requires infrequent changing or adjustment
Well tolerated in ICU patients, enhances patient comfort, and minimizes pressure injuries

**Table 4: Links and Resources related to Unplanned Extubation (UE)**

Resource	Link
Patient Safety Movement Actionable Patient Safety Solutions for Unplanned Extubation	<a href="https://patientsafetymovement.org/clinical/airway-safety/unplanned-extubation/">https://patientsafetymovement.org/clinical/airway-safety/unplanned-extubation/</a> <small>Accessed on November 15, 2021.</small>
Airway Safety Movement UE Resources	<a href="https://www.airwaysafetymovement.org/sam">https://www.airwaysafetymovement.org/sam</a> <small>Accessed on November 15, 2021.</small>
Childrens’ Hospitals Solutions for Patient Safety Network (SPS Network)	<a href="https://www.solutionsforpatientsafety.org/">https://www.solutionsforpatientsafety.org/</a> <small>Accessed on November 15, 2021.</small>
Patient Safety Movement	<a href="https://patientsafetymovement.org">https://patientsafetymovement.org</a> <small>Accessed on November 15, 2021.</small>

the ICU. Several new methods of high-flow oxygenation via the nasal route can potentially delay or prevent the need for re-intubation by maximizing oxygen delivery.<sup>25,26</sup> Several of these methods also provide continuous positive airway pressure (CPAP) and can be useful in patients at higher risk for airway obstruction

and hypoxemia (i.e., obesity, obstructive sleep apnea). It is important to keep in mind that despite these strategies, many patients will still require re-intubation if oxygenation and/or ventilation remain inadequate after UE.

# Several Medical Societies Involved With Unplanned Extubation Awareness and Prevention

From “Unplanned Extubation,” Preceding Page

### FUTURE DIRECTIONS

Unplanned extubation is an often an under-recognized and costly problem in the perioperative environment. Increasing awareness and preventive strategies are vital to address this problem. Better tracking, addition of core data sets in the electronic medical record, and quality improvement initiatives may make an impact on addressing this issue. The Patient Safety Movement Foundation (PSMF) includes UE as one of several important topics to address, as part of achieving a culture of safety.<sup>27</sup> The PSMF, in addition to their Blueprints for Actionable Patient Safety Solutions, makes available educational, evidence-based resources and a coaching program to help hospitals develop a culture of safety, institute quality improvement programs, track UE, and decrease the incidence of unplanned extubation.<sup>27,28</sup>

The Society for Airway Management, a global medical society devoted to improving airway safety, created a special projects committee to address UE. This committee formed a coalition with 20 medical societies and patient safety organizations to increase awareness of UE (Table 5). The coalition has published over 30 articles on UE and developed a toolkit consisting of checklists and core data sets that hospitals can use to track UE. The special projects committee and coalition have also partnered with the PSMF to create blueprints for Actionable Patient Safety Solutions (APSS) specifically addressing UE in both the adult and pediatric/neonatal populations. These resources are updated yearly and can be accessed free of charge from [airwaysafetymovement.org](http://airwaysafetymovement.org) or [patientsafetymovement.org](http://patientsafetymovement.org).

The Coalition has also collaborated with the two newly created patient safety networks, The Children’s Hospitals’ Solutions for Patient Safety Network (SPS Network) and The Adult Hospital Solutions for Airway Safety Network. The Children’s SPS Network consists of over 135 children’s hospitals that are collaborating to reduce harm by sharing quality improvement methods and best practices to reduce UE. The newer Adult Network is modeled after the Children’s SPS Network and is adapting the practices already proven to be effective in children and neonates to the adult population.

*Lauren Berkow, MD, FASA, is a professor and division chief of Neuroanesthesiology at University of Florida College of Medicine in Gainesville, FL. She is also the Immediate past-president of the Society for Airway Management (SAM) and chair of the SAM Special Projects Committee on*

**Table 5: Coalition for Unplanned Extubation Awareness And Prevention Members**

Professional Medical Societies	Patient Safety/Quality Improvement Organizations
American Academy of Pediatrics	Airway Safety Movement
American Association of Respiratory Care	Anesthesia Patient Safety Foundation
American Association of Nurse Anesthetists	Children’s Hospitals’ Solutions for Patient Safety
American College of Emergency Physicians	CMS Strategic Innovation Engine: IMPAQ International
American Society of Anesthesiologists	Do It For Drew Foundation
Association of Air Medical Services	Emergency Medicine Patient Safety Foundation
National Association of EMS Physicians	Patient Safety Movement Foundation
National Association of Emergency Medical Technicians	Pediatric International Patient Safety and Quality Community
National Association of Neonatal Nurses	
Society for Airway Management	
Society of Critical Care Medicine	
Society for Pediatric Anesthesia	

*Unplanned Extubation. She is a board member of the Airway Safety Movement (ASM) and the co-chair of the Patient Safety Movement Foundation’s (PSMF) Unplanned Extubation Workgroup.*

*Arthur Kanowitz, MD, FACEP, is the founder and a Board member of the Airway Safety Movement, the co-chair of the Society for Airway Management’s (SAM) Special Projects Committee on Unplanned Extubation, and the chair of the Patient Safety Movement Foundation’s (PSMF) Airway Safety Workgroup.*

*Conflicts of Interest: Arthur Kanowitz, MD, is the founder and CMO of Securisyn Medical. Lauren Berkow, MD, has no conflicts of interest.*

### REFERENCES

- Asai T, Koga K, Vaughan RS. Respiratory complications associated with tracheal intubation and extubation. *Br J Anaesth.* 1998;80:767–775.
- Domino KB, Posner KL, Caplan RA, et al. Airway injury during anesthesia: a closed claims analysis. *Anesthesiology.* 1999;91:1703–1711.
- Ismaeil MF, El-Shahat HM, El-Gammal MS, et al. Unplanned versus planned extubation in respiratory intensive care unit, predictors of outcome. *Egyptian J Chest Dis Tuberc.* 2014;63:219–231.
- Bouza C, Garcia E, Diaz M, et al. Unplanned extubation in orally intubated medical patients in the intensive care unit: a prospective cohort study. *Heart Lung.* 2007;36:270–276.
- da Silva PS, Reis ME, Aguiar VE, et al. Unplanned extubation in the neonatal ICU: a systematic review, critical appraisal and evidence-based recommendations. *Resp Care.* 2013;58:1237–1245.

- da Silva PS, de Carvalho WB. Unplanned extubation in pediatric critically ill patients: a systematic review and best practice recommendations. *Pediatr Crit Care Med.* 2010;11:287–294.
- McNett M, Kerber K. Unplanned Extubations in the ICU: risk factors and strategies for reducing adverse events. *J Clin Outcomes Manag.* 2015;22:303–311.
- Kapadia FN, Bajan KB, Raje KV. Airway accidents in intubated intensive care unit patients: an epidemiological study. *Crit Care Med.* 2000;28:659–664.
- China AK, Loyd GE, Syzmanski TJ, et al. Frequency and analysis of unplanned extubation in coronavirus disease 2019 patients. *Crit Care Explor.* 2020;24:2:e0291.
- Rapheal J, Rosenthal-Ganon T, Gozal Y. Emergency airway management with a laryngeal mask airway in a patient placed in the prone position. *J Clin Anesth.* 2004;16:560–561.
- Hung MH, Fan SZ, Lin CP, et al. Emergency airway management with fiberoptic intubation in the prone position with a fixed flexed neck. *Anesth Analg.* 2008;107:1704–1706.
- Cosentino C, Fama M, Foà C, et al. Unplanned extubations in intensive care unit: evidences for risk factors. a literature review. *Acta Biomed.* 2017;88:55–65.
- Ai ZP, Gao XL, Zhao XL. Factors associated with unplanned extubation in the intensive care unit for adult patients: a systematic review and meta-analysis. *Intensive Crit Care Nurs.* 2018;47:62–68.
- Piriyapatsom A, Chittawatanarat K, Kongsayreepong S, et al. Incidence and risk factors of unplanned extubation in critically ill surgical patients: The Multi-Center Thai University-Based Surgical Intensive Care Units Study (THAI-SICU Study). *J Med Assoc Thai.* 2016;99:S153–S162.
- Cook TM, Woodall N, Frerck C. Major complications of airway management in the UK: results of the 4th National Audit Project of the Royal College of Anaesthetists and the Difficult Airway Society. Part 1: Anaesthesia. *Br J Anaesth.* 2011;106:617–631.
- Robbertze R, Posner KL, Domino KB. Closed claims review of anesthesia for procedures outside the operating room. *Curr Opin Anaesthesiol.* 2006;19:436–442.

# A Novel Approach for Improving COVID-19 Vaccine Rates: Administration During the Perioperative Period

by Celeste Day, MS, CRNA, and Edward A Bittner, MD, PhD

As of November 13, 2021, the COVID-19 pandemic has infected more than 253 million people worldwide causing more than 5 million deaths. At the time of this writing, the United States alone has had 46 million cases, resulting in 762,000 deaths.<sup>1</sup> The available COVID-19 vaccines have had a positive impact on disease severity and population survival,<sup>2</sup> yet only 59% of the U.S. population that is eligible for the vaccine is fully vaccinated at the time this article was authored.<sup>1</sup> The estimated total cost of this pandemic is 16 trillion USD.<sup>3</sup> A variety of reasons exist for the low rates of vaccination in the United States, which do not necessarily relate to individual refusal. Such reasons can include needle phobia, fear of health care settings, lack of access to vaccination sites, government distrust, long-term safety concerns, and fear of deportation for illegal immigrants.

The preoperative period may be an excellent opportunity to provide COVID-19 vaccine education and offer vaccine administration. Patients may be receptive to education from their perioperative care providers and the convenience of vaccination during their hospital stay. At present, there are no prior reports of COVID-19 vaccination during the perioperative period and no published guidelines. The Center for Disease Control recommends each patient speak to their health care providers about vaccination in relation to surgical or other procedures.<sup>4</sup> The risks of administration of vaccines during the perioperative time period and the benefits of vaccination must be weighed, taking into account the potential immune response to vaccination and effect on surgical healing.<sup>5</sup>

**Table 1: Protocol for Perioperative COVID-19 Vaccination**

1. Screen patient for vaccine status, thanking the vaccinated and providing vaccine teaching to the unvaccinated.
2. Ask patient about willingness to receive the vaccine, excluding contraindications.
3. Discuss with surgeon/proceduralist.
4. Contact pharmacy and identify vaccine options available, ordering available vaccine, obtaining the dose and vaccine card through our facility's process.
5. Administer vaccine during perioperative period, in contralateral deltoid muscle if surgical site is a factor. For needle phobic patients, this can occur during anesthesia.
6. Document vaccination in medical record and on vaccine card. Provide patient with vaccine card and date for second administration.
7. Provide information regarding vaccine side effects and contact information for questions/concerns.

In collaboration with the Anesthesia and Surgical Teams, Nursing and the OR Pharmacy, here at the Massachusetts General Hospital, the authors developed a protocol (Table 1) for perioperative COVID-19 vaccination. To date five patients (Table 2) have actively sought COVID-19 vaccination and have been provided a first dose during the perioperative period. During the one-month period between September 15, 2021, to October 15, 2021, in caring for 94 patients, the authors encountered eight unvaccinated patients during regular anesthesia practice. Among this cohort, 50% of the

unvaccinated patients were open to receiving vaccination. We have been able to accommodate each of these requests with the availability of vaccine doses at the time of request in our central pharmacy. No untoward side effects have been reported after vaccine administration at the present time. Vaccine cards were filled out and distributed to patients with instructions given to assist with scheduling second vaccine appointments in collaboration with primary surgical teams, patients, and caregivers.

Vaccination administration during anesthetic care may be an effective way to improve vaccination compliance, patient, and population wellness. While the number of unvaccinated patients presenting for surgery is unknown, it is likely to approximate the 40% of unvaccinated patients in the US population overall and even be higher in regions with lower vaccination rates. The patients at MGH who have received these doses had varying reasons to not yet be vaccinated and all were grateful to receive their first dose.

Next steps for the initiative include extending the program more widely across the institution and its affiliates, facilitating second dose administration, and monitoring rates of success. A number of questions remain unanswered including whether there are differences in vaccination efficacy based on surgical procedure type, patient characteristics, and the optimal timing of administration during the perioperative period. Such questions warrant study on a larger scale.

See "Vaccine Rates," Next Page

**Table 2: Patient Characteristics and Reasons for Perioperative Vaccination**

Age	Gender	ASA Classification	Surgical Procedure	Reason for Perioperative Vaccination Request	Timing of vaccination
52	Female	2	Bilateral mastectomy with lymph node dissection for cancer	Needle phobic and requesting vaccination under general anesthesia. She stated that she would then follow up for her second dose having received the first dose	Intraoperative
32	Female	3	Left foot debridement and vacuum-assisted closure (VAC) dressing placement	Limited access to resources	Intraoperative
63	Male	4	Right index finger amputation	Just learned of an unvaccinated friend who died of COVID-19	Postoperative (vaccination dose was not ready during surgery)
18	Female	3	Laparoscopic sleeve gastrectomy	Developmental delay and limited access to resources	Intraoperative
55	Female	2	Right upper arm Schwannoma excision	Vaccination anxiety	Postoperative (vaccination dose was not ready during surgery)



## Perioperative Vaccination Program May Increase Overall Vaccination Rates

From "Vaccine Rates," Preceding Page

Despite large population-wide vaccine efforts, a significant number of people remain unvaccinated during the COVID-19 pandemic. A prime opportunity for perioperative providers to join together to improve the health of our unvaccinated patients and our society with vaccination is present. We encourage institutions worldwide to join in these efforts by establishing their own vaccination programs.

*Celeste Day, MS, CRNA, is a senior nurse anesthetist at Massachusetts General Hospital, Boston, MA.*

*Edward A Bittner MD, PhD, MSED, is an associate professor of Anesthesia, Harvard Medical School, Massachusetts General Hospital, Boston, MA. He is associate editor of the APSF Newsletter.*

*The authors have no conflicts of interest.*

### REFERENCES

1. Johns Hopkins University of Medicine Coronavirus Resource Center. <https://coronavirus.jhu.edu/>. Last accessed November 13, 2021.
2. Centers for Disease Control and Prevention COVID-19 Vaccine Effectiveness. <https://www.cdc.gov/coronavirus/2019-ncov/vaccines/effectiveness.html>. Last accessed November 13, 2021.
3. Cutler DM, Summers LH. The COVID-19 Pandemic and the \$16 Trillion Virus. *JAMA*. 2020;324:1495–1496. <https://jamanetwork.com/journals/jama/fullarticle/2771764>.
4. Centers for Disease Control and Prevention COVID-19 Vaccines and Other Procedures. <https://www.cdc.gov/coronavirus/2019-ncov/vaccines/expect/other-procedures.html>. Last accessed November 13, 2021.
5. Lin C, Vazquez-Colon C, Geng-Ramos G, Challa C. Implications of anesthesia and vaccination. *Paediatr Anaesth*. 2021;31:531–538.

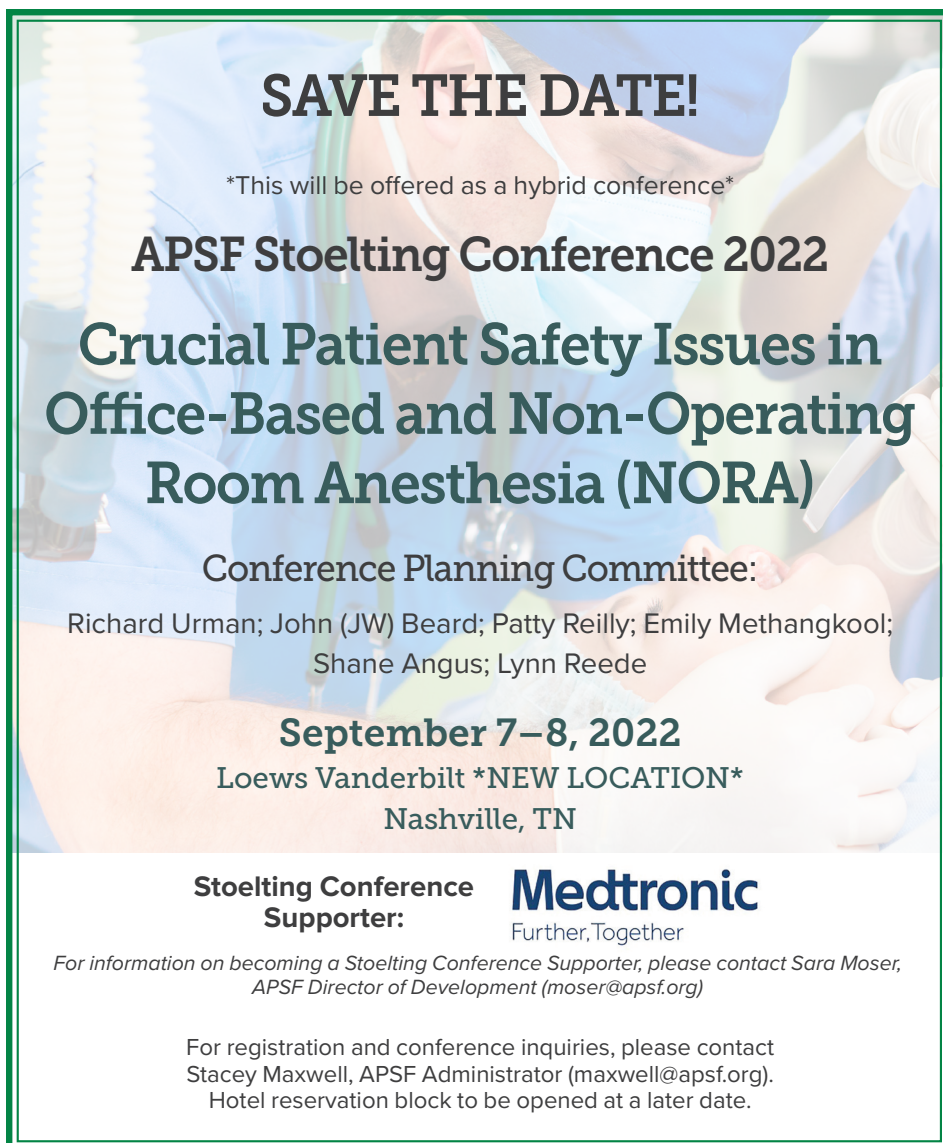

**SAVE THE DATE!**

\*This will be offered as a hybrid conference\*

**APSF Stoelting Conference 2022**

**Crucial Patient Safety Issues in Office-Based and Non-Operating Room Anesthesia (NORA)**

Conference Planning Committee:  
Richard Urman; John (JW) Beard; Patty Reilly; Emily Methangkool;  
Shane Angus; Lynn Reede

**September 7–8, 2022**  
**Loews Vanderbilt \*NEW LOCATION\***  
**Nashville, TN**

**Stoelting Conference Supporter:** **Medtronic**  
Further, Together

*For information on becoming a Stoelting Conference Supporter, please contact Sara Moser, APSF Director of Development (moser@apsf.org)*

For registration and conference inquiries, please contact Stacey Maxwell, APSF Administrator (maxwell@apsf.org).  
Hotel reservation block to be opened at a later date.

## Unplanned Extubation (References cont'd)

From "Unplanned Extubation," Page 16

17. Chao CM, Sung MI, Cheng KC, et al. Prognostic factors and outcomes of unplanned extubation. *Sci Rep*. 2017;7:8636.
18. Mort TC. Unplanned tracheal extubation outside the operating room: a quality improvement audit of hemodynamic and tracheal airway complications associated with emergency tracheal reintubation. *Anesth Analg*. 1998;86:1171–1176.
19. de Lassence A, Alberti C, Azoulay E, et al. Impact of unplanned extubation and reintubation after weaning on nosocomial pneumonia risk in the intensive care unit: a prospective multicenter study. *Anesthesiology*. 2002;97:148–156.
20. Needham DM, Pronovost PJ. The importance of understanding the costs of critical care and mechanical ventilation. *Crit Care Med*. 2005;33:1434–1435.
21. Dasta J, McLaughlin T, Mody S, Piech C. Daily cost of an ICU day. *Crit Care Med* 2005;33:1266–1271.
22. Vats A, Hopkins C, Hatfield K, et al. An airway risk assessment score for unplanned extubation in intensive care pediatric patients. *Pediatr Crit Care Med*. 2017;18:661–666.
23. Kandil SB, Emerson BL, Hooper M, et al. Reducing unplanned extubations across a children's hospital using quality improvement methods. *Pediatr Qual Saf*. 2018;3: e114.
24. Gardner A, Hughes D, Cook R, et al. Best practices in stabilization of oral endotracheal tubes: a systematic review. *Aust Crit Care*. 2005;18:160–165.
25. Patel A, Nouraei SA. Transnasal Humidified Rapid-Insufflation Ventilator Exchange (THRIVE): a physiological method of increasing apnoea time in patients with difficult airways. *Anaesthesia*. 2015;70:323–329.
26. Jaber S, Monnin M, Girard M, et al. Apnoeic oxygenation via high-flow nasal cannula oxygen combined with non-invasive ventilation preoxygenation for intubation in hypoxaemic patients in the intensive care unit: the single-centre, blinded, randomised controlled OPTINIV trial. *Intensive Care Med*. 2016;42:1877–1887.
27. <https://patientsafetymovement.org/wp-content/uploads/2016/02/APSS-1-Culture-of-Safety-copy.pdf>
28. <https://patientsafetymovement.org/clinical/creating-a-foundation-for-safe-and-reliable-care/>

## RAPID Response

to questions from readers

# Thermal Injury After Use of a Convective Warming System

by Luke S. Janik, MD, and Ryan Lewandowski, SRNA

### Dear RAPID Response:

Two consecutive patients suffered similar thermal injuries to the upper extremity and chest after the use of a convective warming system. Both patients underwent a laparoscopic robotic prostatectomy in the Trendelenberg position with the arms tucked. The cases were performed sequentially in the same operating room, with the same personnel. In both cases, a Smiths Medical EQUATOR® Level 1® Convective Warming System was used in conjunction with the Snuggle Warm® Small Upper Body Convective Warming Blanket. The upper body warming blanket was secured to the patient with the built-in adhesive strip, placed just caudad to the nipple line. No additional blankets were placed on top of (or underneath) the warming blanket. The “arms” of the warming blanket were tucked into the crease between the operating room table and cushions since the patient’s arms were tucked. The hose was then connected to the warming blanket at the blanket port connection near the left shoulder, and the hose suspended with a retaining clip (Figure 1). Of note, in one of the cases, it was confirmed that the air manifold was inadvertently missing. The air manifold is an “elbow” shaped plastic tube connected to the end of the warming hose, with several openings on the distal end designed to evenly disperse warm air over the patient (Figure 2, Panel A). The warming device was set

to a temperature of 44° Celsius (high setting) throughout both cases. Intraoperatively the warming device appeared to function normally, without audible or visual alarms. Both patients were hemodynamically stable and normothermic by nasopharyngeal temperature monitoring throughout. In recovery, both patients were noted to have diffuse erythema on the left upper extremity and chest, in close proximity to the site of the blanket port connection. On postoperative day one, blistering developed on the shoulder and chest of both patients (Figure 3), which ultimately resolved with conservative management.

### DISCUSSION

Convective warming systems are commonly used to prevent hypothermia.<sup>1,2</sup> Hypothermia has been linked to increased surgical site infections, blood loss, and cardiac events. *The Centers of Medicare & Medicaid Services* recently added “Perioperative Temperature Management” as a core anesthesia measure, requiring postoperative temperatures of >35.5° Celsius for procedures over 60 minutes.

Thermal injuries are rare when manufacturer’s instructions are followed.<sup>3</sup> When thermal injuries do occur, they are often the result of improper use of the device.<sup>4-6</sup> The most common form of improper use occurs when the hose is positioned on or adjacent to the patient’s skin, without the use of a warming

blanket. The Smiths Medical EQUATOR® Level 1® Convective Warming System is equipped with several safety features to reduce the risk of thermal injury, including “Over Temperature” alarms, a maintenance indicator, and an occlusion indicator.

In the cases presented here, the cause of the thermal injury remains under investigation. The pattern of injury suggests a focal area of overheating at the point where the hose connects to the warming blanket. We believe there could have been a faulty “Over temperature” alarm. According to the Operator’s Manual, “the safety thermistor activates and alarms if the temperature reaches 3° Celsius above set point...the circuit provides an independent means of shutoff, which discontinues power to the heater and blower.” Though many factors contribute to the development of a thermal injury (temperature, duration of exposure, etc.), one potential explanation in these cases could be that the temperature of the air was higher than the alarm set point of 47° Celsius. Another possible contributing factor is the inadvertent absence of the air supply manifold (confirmed in one of the cases). According to the Operator’s Manual, the air manifold “distributes the warmed air to delivery channels in a pattern designed to promote heat transfer to the patient... perforations on the patient side of the air delivery channel gently disperse warm air over the patient thereby maintaining patient temperature”. The absence of the air manifold likely resulted in the concentrated delivery of warmed air onto a small surface area of the patient, explaining the pattern of injury. Since two identical devices were present in that operating room on the day of injury, both devices were returned to Smiths Medical for further investigation (even though we suspect the same device was the culprit for both cases). The results of their investigation are ongoing.

See “Thermal Injury,” Next Page

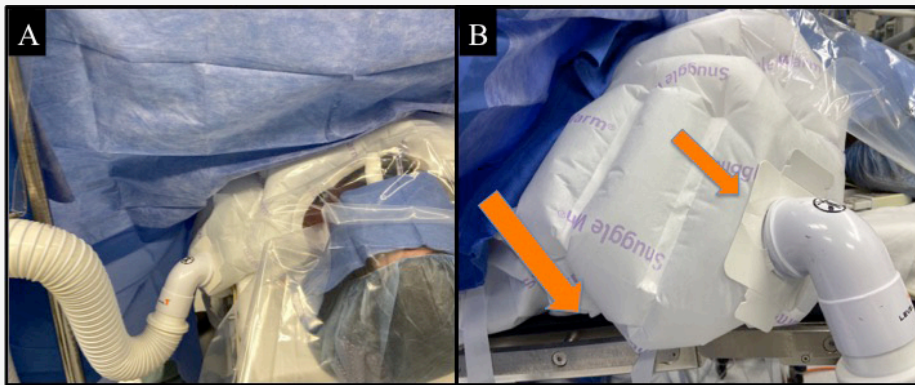

Figure 1: Panel A demonstrates the configuration of the warming device in these cases, with the warming hose connected to the upper body warming blanket connection port near the left shoulder. The warming hose is suspended with a retaining clip. Panel B orange arrows highlight the “arms” of the warming blanket tucked into the crease between the operating room table, and the connection port near the patient’s left shoulder.



# Convective Warmer-Related Thermal Injury

**From “Thermal Injury,” Preceding Page**

These cases provide an opportunity to open a dialogue with Smiths Medical in an effort to improve patient safety. First, we ask that Smiths Medical comment on the importance of the air manifold. Figure 2 demonstrates how the hose and air manifold can be disassembled, and how the hose is capable of connecting to the warming blanket directly, without the air manifold. If the air manifold piece is critical to the safe function of the device, why is it removable? If it must be removable, should there be a circumferential “warning label” visible on the end of the hose to alert the user to the potential danger of connecting directly to the blanket port (Figure 2, Panel C)? Alternatively, has the manufacturer considered a “forcing function” that would prevent the hose from connecting to the blanket port without the use of the air manifold (i.e., akin to the way a diesel fuel pump cannot be inserted into a regular fuel tank)?

Next, we ask Smiths Medical to reply to several questions regarding the Operator’s Manual for the EQUATOR® Level 1® Convective Warmer, which contains an extensive list of warnings intended to avoid patient injury. Many of these warnings are intuitive and are part of routine care, but some of them are difficult to reconcile with the realities of clinical care, as discussed below:

*“To prevent thermal injury, do not use the highest temperature setting when treating patients who have decreased sensation, are nonsensate, or have poor perfusion.”*

Patients under general anesthesia are nonsensate by definition, yet they require active warming to avoid hypothermia. Is the manufacturer suggesting that the highest temperature setting be avoided altogether in patients under general anesthesia?

*“Always start therapy on the lowest non-ambient temperature setting to prevent thermal injury. Increase the temperature setting, if required, using core body temperature and cutaneous response of skin in contact with the convective warming blanket as indicators.”*

The convection warmer is commonly started at the highest setting to prevent rapid heat loss from radiation, conduction, convection, and evaporation. Does the manufacturer advise against this practice? If so, are there any exceptions where starting on the high setting would be justified (e.g., a trauma patient with large surgical exposure at risk for significant hypothermia and associated coagulopathy)? Is there a minimum required time at each setting before escalating to the next?

*“...Observe cutaneous response at regular intervals to prevent thermal injury. If erythema or instability in vital signs is evident, decrease the temperature setting or discontinue use of the convective warming therapy.”*

Recognizing a developing thermal injury can be difficult or impossible for even the most vigilant anesthesia professional, because clinical signs may not be present until well after the injury has occurred. In addition, the site is often inaccessible or covered by the warming blanket itself or the surgical drapes. Furthermore, the lighting in an operating room may be dimmed, making detection of subtle erythema challenging.

The manufacturer’s suggestion that instability in vital signs warrants discontinuation of the warming therapy likely oversimplifies the complex physiological perturbations during anesthesia and surgery. The differential diagnosis of intraoperative vital sign instability is broad, and discontinuation of the warming therapy may be contraindicated in certain situations (e.g., a patient who is hypotensive due to hemorrhagic shock, in which coagulopathy may be worsened by hypothermia).

See “Thermal Injury,” Next Page

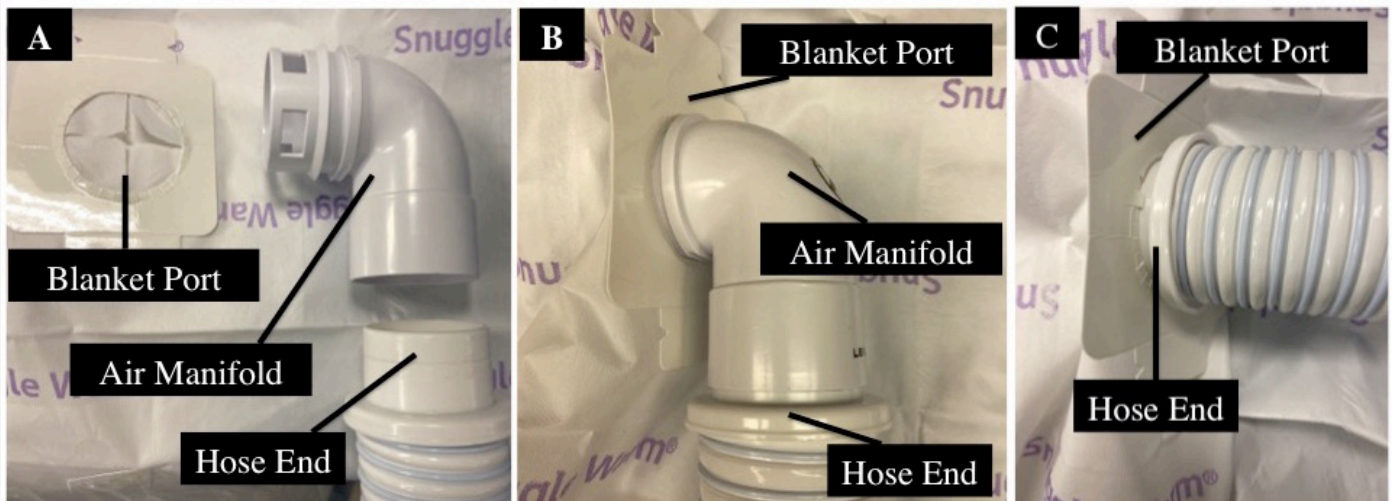

Figure 2: Panel A shows the hose end disassembled from the air manifold. Note the perforations at the distal end of the air manifold, which distribute airflow throughout the warming blanket. Panel B demonstrates the proper connection of hose end to the air manifold, which in turn connects to the blanket port. Panel C demonstrates how the hose end can be (inadvertently) inserted directly into the blanket port if the air manifold is missing.

The information provided is for safety-related educational purposes only, and does not constitute medical or legal advice. Individual or group responses are only commentary, provided for purposes of education or discussion, and are neither statements of advice nor the opinions of APSF. It is not the intention of APSF to provide specific medical or legal advice or to endorse any specific views or recommendations in response to the inquiries posted. In no event shall APSF be responsible or liable, directly or indirectly, for any damage or loss caused or alleged to be caused by or in connection with the reliance on any such information.



**RAPID Response**  
to questions from readers

# Convective Warmer-Related Thermal Injury

From “Thermal Injury,” Preceding Page

*“To prevent thermal injury, do not allow any of the patient’s body parts to rest on the active hose inlet”*

The design of the Snuggle Warm® blanket inherently places the active hose inlet in close proximity to the patient’s shoulder. Has the manufacturer considered modifying the design of the warming blanket, so that the connection port is more distant to the patient (i.e., creating an “elephant trunk” type extension)? When the patient’s arms are positioned at their side, it is common practice to tuck the edges of the upper body warming blanket into the crease between the operating room table and the cushions. Does this practice restrict airflow and increase the risk of thermal injury? If so, what recommendations does the manufacturer have for upper body blanket use in a patient with the arms tucked?

Our department has taken widespread measures to raise awareness of these safety concerns, and issued the following recommendations to anesthesia team members:

- Always confirm the presence of the air manifold component prior to connecting the hose to the warming blanket.



Figure 3: Blisters noted on post-operative day one (patient consent obtained for use of this image).

- Start with the medium temperature setting (40° Celsius) unless otherwise indicated.
- Use caution to avoid airflow restriction within the warming blanket.

We invite Smiths Medical to respond to this report, and welcome their suggestions regarding the safe use of convective warming systems.

Sincerely,  
Luke S. Janik, MD  
Ryan Lewandowski, SRNA

Luke S. Janik, MD, is presently clinical assistant professor in the Department of Anesthesia and Critical Care at the University of Chicago, and an attending anesthesiologist in the Department of Anesthesiology, Critical Care, and Pain Medicine at NorthShore University HealthSystem in Evanston, IL.

Ryan Lewandowski, SRNA, is presently a student registered nurse anesthetist at NorthShore University HealthSystem School of Nurse Anesthesia in Evanston, IL.

The authors have no conflicts of interest.

### REFERENCES

1. Ohki K, Kawano R, Yoshida M, et al. Normothermia is best achieved by warming above and below with pre-warming adjunct: a comparison of conductive fabric versus forced-air and water. *Surg Technol Int*. 2019;34:40–45.
2. Nieh HC, Su SF. Meta-analysis: effectiveness of forced-air warming for prevention of perioperative hypothermia in surgical patients. *J Adv Nurs*. 2016;72:2294–2314.
3. Bräuer A, Quintel M. Forced-air warming: technology, physical background and practical aspects. *Curr Opin Anaesthesiol*. 2009;22:769–774.
4. Chung K, Lee S, Oh SC, et al. Thermal burn injury associated with a forced-air warming device. *Korean J Anesthesiol*. 2012;62:391–392.
5. Uzun G, Mutluoglu M, Evinc R, et al. Severe burn injury associated with misuse of forced-air warming device. *J Anesth*. 2010;24:980–981.
6. Truell KD, Bakerman PR, Teodor MF, Maze A. Third-degree burns due to intraoperative use of a Bair Hugger warming device. *Ann Thorac Surg*. 2000;69:1933–1934.

## IN RESPONSE:

# Convective Warming Systems—Maintaining Normothermia in the Operating Room

by Jesús A. Cabrera, MD, PhD

Thank you for engaging with Smiths Medical regarding our Level 1® Equator® Convective Warming Device and Level 1 Snuggle Warm® Convective Warming Blanket. We received the report of two patients who experienced burn injuries during robotic prostatectomy surgery. Fortunately, the injuries resolved with conservative treatment and did not result in permanent injury. At Smiths Medical, our top priorities are always quality and patient safety, and this report provides an opportunity to partner with our customers and the patient safety community to investigate the potential causes.

Smiths Medical follows standard procedures to investigate product complaints and patient

safety concerns. In accordance with these procedures, we requested the products in question to be returned for evaluation. The two returned devices were thoroughly tested and found to perform within specifications. The alarm systems were also assessed and found to be functioning within specifications.

As part of our procedure, we also reviewed our Periodic Safety Update Report (PSUR), which includes available post-market data for the previous five years regarding the safety and performance of the marketed products. The products in question have been in use globally for more than 10 years, and in the past five years, Smiths Medical sold more than 40

million blankets. The PSUR review did not identify any recurrent patient safety issues that would suggest a need to modify the risk/benefit concerns and the product was determined to be acceptable for manufacture, sale, and distribution. The PSUR is an ongoing regularly scheduled safety assessment.

Following the assessment that the two devices were performing within specifications by Smiths Medical Service and Repair personnel, we were asked to opine upon these cases and offer suggestions to anesthesia professionals regarding safe use of convection warming devices.

See “Convection Warming Systems,” Next Page

The information provided is for safety-related educational purposes only, and does not constitute medical or legal advice. Individual or group responses are only commentary, provided for purposes of education or discussion, and are neither statements of advice nor the opinions of APSF. It is not the intention of APSF to provide specific medical or legal advice or to endorse any specific views or recommendations in response to the inquiries posted. In no event shall APSF be responsible or liable, directly or indirectly, for any damage or loss caused or alleged to be caused by or in connection with the reliance on any such information.

## Convective Warming Systems

From “Convection Warming Systems,”  
 Preceding Page

In reviewing Janik et al.'s manuscript, it is reassuring that his department has positive and successful experiences with these devices for greater than a decade. Furthermore, our sales representative had the privilege of interacting with the clinical team at NorthShore. Based on the report and our discussion with the clinical team we would offer the following commentary.

First, I am in complete agreement with Janik's statement that thermal injuries are rare when manufacturer's instructions are followed. In the Equator's Operating Manual, the section named “Important Safety Information” includes a warning stating that “The hose nozzle MUST be connected to a Snuggle Warm convective warming blanket. Do not treat patients with the hose alone. Thermal injury may occur.” In the section named “Operating Instructions,” Step 4 illustrates the attachment of the hose nozzle to the convective warming blanket.<sup>1</sup> (Figure 1)

Smiths Medical also published a document entitled “Equator Convective Warming System Step-by-Step Guide.”<sup>2</sup> This guide also illustrates the proper connection of the hose nozzle into the collar ring of the blanket.

Janik et al. notes the hose nozzle (air manifold) was missing on one device and that the hose was directly connected to the blanket. As noted, this manifold is designed to ensure a proper connection of the hose to the blanket and distribute the air evenly. For clarification, it is not designed to cool the warmed air, as suggested by Janik and Lewandowski.

Another consideration is the potential patient safety implications associated with robotic prostatectomy. A number of concerns for robotic-assisted prostatectomy have been reviewed in the anesthetic literature. Danic et al.<sup>3</sup> and Gainsburg<sup>4</sup> both described the complications that can arise associated with the extreme lithotomy and steep Trendelenberg positioning common in this procedure. For example, they both note the potential for nerve injuries. Maintaining normothermia is an important goal of anesthetic care facilitated with the use of a convection warmer. This report raises the question that thermal injury may be another potential complication associated with

### Step 4: Attach the Hose to Convective Warming Blanket

#### WARNING

The hose nozzle **MUST** be connected to a Snuggle Warm® convective warming blanket. Do not treat patients with the hose alone. Thermal injury may occur.

- 1 Insert the hose nozzle (a) into the collar ring (b).
- 2 Ensure the hose barb (c) snaps into the collar ring (b).
- 3 If the hose has locking tabs (d), secure the hose to the convective warming blanket using the hose retainer wings (e). The hose tabs will protrude through the retainer wings (e).

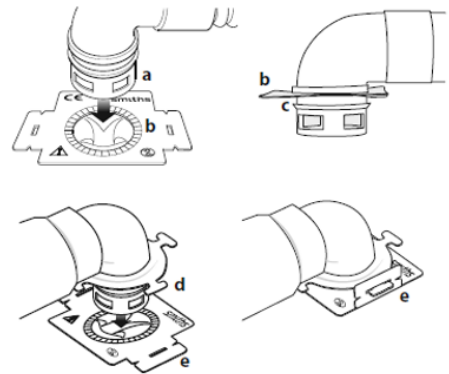

Figure 1: Instructions for Hose Nozzle Connection into the Collar Ring of the Blanket from the Operators Manual—Equator Convective Warmer (page 14).

robotic prostatectomy. Secure placement of the hose nozzle is important to the safe use of this product and may be difficult in this procedure. Furthermore, tucking the warming blanket to the patient's sides has the potential to restrict airflow. If the nozzle is not well secured to the blanket as designed, and the flow into the blanket restricted, one could imagine a jet of hot air continuously projected upon the skin surface for a length of time sufficient to cause a burn injury, as described in the Warnings of the Operator's Manual.

The clinical team at NorthShore University HealthSystem graciously invited our sales representatives into their facility. In the conversations between the clinical team and Smiths Medical, it was found that there were hose nozzles that were missing on a number of devices and replacements have been delivered to that institution.

We are proud that the Level 1 Equator Convective Warming Systems have a long history of safe and effective use for more than 10 years in operating theaters around the globe. I believe the complaints presented here illustrate important learning points. The hose nozzle is a critical part designed to assure a good connection

between hose and blanket to safely deliver warming therapy to patients. This report is a reminder to inspect and evaluate the Equator's within operating theaters to assure hose nozzles are present and used as described in the Operating Manual. Also, patient positioning can make it difficult to use devices as intended and in accord with recommended operating procedures. As described in the user's manual, the highest setting of output temperature should only be used when rapid correction of hypothermia is essential and then only for as long as necessary.

Jesús A. Cabrera, MD, PhD  
 Senior Director Medical Affairs  
 Smiths Medical, ASD  
 6000 Nathan Ave N  
 Minneapolis, MN

#### REFERENCES:

1. Smiths Medical Operator's Manual Equator Convective Warmer 2019. Part Number: 10010811-004.
2. Smiths Medical Level 1 Equator Convective Warming System: Step-by-Step Guide.
3. Danic MJ, Chow M, Alexander F, et al. Anesthesia considerations for robotic-assisted laparoscopic prostatectomy: a review of 1,500 cases. *J Robotic Surg.* 2007;1:119–123.
4. Gainsburg DM. Anesthetic concerns for robotic-assisted laparoscopic radical prostatectomy. *Minerva Anesthesiol.* 2012;78:596–604.

## RAPID Response

to questions from readers

# Convection Warmers and Burn Injury—Still A Clear and Present Danger

by Jeffrey Feldman, MD, MSE

Convection warmers are a well-established therapeutic adjunct in the operating room, helping to maintain normothermia safely for millions of patients every year. These devices increase body temperature by transferring heat to the skin where it is absorbed by the blood and distributed to the rest of the body. Burns can occur when the heat applied to the skin is high enough to cause injury and exceeds the capacity of the blood to absorb it. We learned many years ago that clinical convection warmers produce sufficient heat to cause a significant burn injury if the outlet hose is directed to the skin without a warming blanket to disperse the heat, a practice called “hosing.” Fortunately, with education, the risk of hosing is well-known and patients should no longer be injured in this fashion.

In this issue of the *Newsletter*, Janik and Lewandowski report two cases where patients suffered a burn injury with the use of a warming blanket. They identified in their report potential causes, which include malfunction of the warming device and lack of a nozzle to disperse the heated air for one of the patients. They also raised some questions about the applicability of safety warnings in the operator’s manual to the practice of anesthesia. We are fortunate to have a response from the manufacturer, Smiths Medical, confirming that the devices used to care for these patients were functioning within specifications. Smiths Medical also has taken action to ensure that proper hose connectors are available at the original authors’ institution and reminds users of the device to ensure those connectors are in place when using the device.

It is clear, however, that for convection warmers to be effective, they must produce a certain amount of heat that can cause an injury if the device is not used properly. It is incumbent upon the clinicians at the bedside to understand how to safely apply this important therapy. Because of the positioning requirements of robotic prostatectomy and the design of the warming disposable blanket, the warming “arms” had to be tucked around the patient.

Whether or not the tucking impaired distribution of heated air through the disposable, concentrating heat at the inlet site and contributing to the burn injury is not certain. We do know from the hosing experience that the disposable warming blanket is critical to mitigating the risk of burns, and this report raises the question of the risk when the disposables cannot be used exactly as designed.

What can we learn from these reports that we can implement at the bedside to eliminate the risk of burn injuries? Certainly, we do not want to stop using this highly effective technology. Further, we need to continue to use the warming blankets. The existing safety warnings however are instructive, particularly the warning to “not use the highest temperature setting when treating patients who have decreased sensation, are nonsensate, or have poor perfusion.” While using the highest setting is common practice during anesthesia care, many patients may well be sufficiently warmed using the medium setting only or by using the high setting for a limited period of time. Given the information in these reports, there are a few recommendations to consider when using convection warmers to reduce the risk of burn injury:

1. Never use the hose without a warming blanket properly connected. (We know that!)
2. Reserve the highest temperature setting for patients who are significantly hypothermic and require rapid correction.\*
3. Use the highest temperature setting for the shortest duration required to reach a clinically acceptable temperature.
4. The temperature setting selected for convection warmers should be guided by simultaneous measurement of body temperature with an internal temperature probe, especially when the highest output setting is used.

\*NOTE: There are no data to guide the rate at which temperature should be corrected. Normothermia is the ultimate goal. Clinical judgement continues to be the best guide. In this author’s opinion, mild hypothermia

(35–36 degrees celsius) likely does not require rapid correction with the highest temperature setting. More significant hypothermia (<35 degrees celsius) likely warrants more aggressive correction, but the temperature setting can likely be reduced when the body temperature increases to greater than 35 degrees celsius. Factors like the ambient temperature and the amount of body surface that can be warmed will also influence the temperature setting required to achieve normothermia.

*Jeffrey M. Feldman, MD, MSE, is an attending anesthesiologist at the Children’s Hospital of Philadelphia and professor of clinical anesthesiology at the Perelman School of Medicine, University of Pennsylvania*

*Jeffrey Feldman, MD, has consulting relationships with Micropore USA, Becton-Dickinson, and Medtronic.*

## SUPPORT YOUR APSF

### Your Donation:

- Funds Research Grants
- Supports Your APSF Newsletter
- Promotes Important Safety Initiatives
- Facilitates Clinician-Manufacturer Interactions
- Supports the Website

Donate online  
(<https://www.apsf.org/donate/>) or  
mail to

APSF  
P.O. Box 6668  
Rochester, MN 55903  
U.S.A.



# A Practical Approach to Fostering Clinician Well-Being in an Academic Anesthesiology Department

by Jina Sinskey, MD; Joyce Chang, MD; Megha Parekh, MD; and Michael Gropper, MD, PhD

## THE MISSION OF ACADEMIC MEDICINE

The mission of academic medicine is to advance the field of medicine and provide excellent patient care. There are three major academic spheres: medical education, scientific inquiry, and leadership. Clinician burnout has negative personal and professional consequences, including substance use disorders, decreased quality of care, and increased medical errors.<sup>1</sup> Thus, clinician well-being may translate to increased clinician and patient safety. Here we share our department's experience and discuss how anesthesiology departments can promote clinician well-being in these three realms.

Since clinician well-being is about supporting our people, it is important to understand why clinicians choose to pursue a career in academic medicine. Clinicians may choose to enter academic medicine because they want additional roles and responsibilities beyond core clinical care, most commonly in medical education and research. Clinicians may also wish to pursue administrative and leadership roles, and the distribution between these different roles may vary based on their interests. Anesthesiology departments must provide flexibility and opportunities for clinicians to pursue these roles. Spending at least 20% of time at work (i.e., 1 day/week) on activities that are most meaningful may be protective against burnout.<sup>2</sup>

The National Academy of Medicine (NAM) recommends that health care systems and academic institutions should create positive work and learning environments,<sup>3</sup> emphasizing the need to create an inclusive culture that empowers all clinicians to bring their authentic selves. Thus, well-being efforts are intimately connected with efforts to promote diversity, equity, and inclusion.

## MEDICAL EDUCATION

Academic institutions have the immense privilege and responsibility of training the next generation of clinicians. To better equip clinicians for a fulfilling career in medicine, well-being should be taught as a core curriculum topic during medical training. At our institution, we have a residency well-being curriculum spanning three years that incorporates didactic sessions and small group discussions on professional development and well-being topics such as facing failure, emotional processing, self-compassion, and conflict management.<sup>4</sup>



Academic anesthesiology departments must cultivate a culture of support to foster both faculty and learner well-being. Faculty well-being is essential for learner well-being since faculty drive institutional culture and serve as role models for learners. Faculty value opportunities for connection and professional development, and our department has several programs to support these needs. The Visiting Scholars in Pediatric Anesthesia Program (ViSiPAP) is a national faculty and fellow exchange program created by our department to provide opportunities for community building and academic advancement.<sup>5</sup> The ViSiPAP program has been demonstrated to enhance well-being, improve didactic conferences, and provide opportunities for networking and collaborating.<sup>6</sup> By encouraging collaboration and knowledge sharing across institutions, this program has the potential to improve the practice of anesthesiology to provide safer patient care.

Within our department, we have established a Clinical Seed Fund to support clinical faculty who wish to engage in research. This is a program where new investigators with higher clinical commitments can apply for departmental funding and nonclinical time to pursue a research project. In addition, we have formed an Anesthesia Biostatistics and Clinical Design group that includes anesthesiology faculty with research expertise who provide formal and informal research advice and mentorship. We

have created a series of professional development workshops for faculty to achieve career success, with topics such as creating an individual development plan, using social media for advancement, mentorship, and time management. We also have financial well-being workshops to help faculty and learners achieve their financial goals, since it has been shown that medical student debt is negatively associated with mental well-being.<sup>7</sup>

## SCIENTIFIC INQUIRY

The NAM recommends that health care systems invest in research on clinician well-being.<sup>3</sup> Research questions proposed by the NAM include factors that contribute to burnout and well-being, implications of clinician and learner distress, and system-level interventions to improve well-being. Clinician well-being research incorporates existing research methodologies such as epidemiology, implementation science, quantitative research, and qualitative research. Academic departments often have existing infrastructure such as research networks and administrative support in place to support well-being research programs and are well-positioned to lead early research efforts. Collaboration between academic and nonacademic institutions can further accelerate research in clinician well-being.

See "Clinician Well-Being," Next Page

# Addressing Perioperative Clinician Well Being Requires All Stakeholder Engagement

## From “Clinician Well-Being,” Preceding Page

Since 1996, our department has received a T32 institutional training grant from the National Institutes of Health (NIH) to train a new generation of anesthesia professionals with expertise in research fundamentals. In 2021, we received an administrative supplement from the NIH to create a well-being program for anesthesia research trainees. This new program includes community building events, career mentorship, well-being research seminars, and a map of well-being resources for anesthesiology research trainees. In addition, the T32 program leadership is conducting qualitative research to determine drivers of well-being and burnout in anesthesiology research trainees and assess the effectiveness of the well-being program.

## LEADERSHIP

Leaders can promote well-being in their department by developing a guiding approach, building a team, and communicating regularly. Open lines of communication are more important than ever before. Leaders should communicate transparently about ongoing initiatives, provide the rationale for crucial decisions, communicate when problems arise, and share solutions.

Investments in well-being must be balanced with other financial components of the department such as clinical compensation, research, and more. This investment represents a long-term strategy that focuses on retention of faculty, since current literature estimates the cost to replace a physician to be 2–3 times the physician’s annual salary.<sup>8</sup> An example of such investment in well-being is funding protected time for faculty well-being positions. Our departmental infrastructure includes an associate chair of well-being who leads departmental efforts, director of faculty and director of learner well-being positions, as well as a steering committee that incorporates representation from all groups of our department. Departmental well-being leaders collaborate closely with leaders in diversity, equity, and inclusion, and academic affairs.

Organizational well-being efforts require a systematic strategic plan to be effective. Our department uses two frameworks to structure our well-being efforts: the six areas of worklife (workload, control, reward, community, fairness, values)<sup>9</sup> and the Modified Maslow’s Hierarchy of Needs for well-being.<sup>10</sup> We have developed a novel, systematic approach incorporating principles of human-centered design, quality improvement, and implementation science that we term Quality of Life Improvement.<sup>11</sup> With our

department’s well-being efforts, our annual faculty satisfaction scores have steadily increased over the past five years.

## OUR VISION FOR THE FUTURE

Organizations can enhance clinician well-being by fostering a supportive work culture and work environment that enable clinicians to focus on patient care. It is important to recognize that well-being efforts do not exist in a vacuum. Efforts to address perioperative clinician well-being require engagement from all stakeholders. With this in mind, we have established a team of anesthesia professionals, surgeons, and nurses to design and implement perioperative well-being interventions. Our hope is that our efforts will promote a systems approach to clinician well-being within our department and beyond.

*Jina Sinskey, MD, is an assistant professor and associate chair of Well-Being of the Department of Anesthesia and Perioperative Care at the University of California, San Francisco, CA. She is also the vice chair of the American Society of Anesthesiologists Committee on Physician Well-Being.*

*Joyce Chang, MD, is an assistant professor and Director of Faculty Well-Being of the Department of Anesthesia and Perioperative Care at the University of California, San Francisco, CA.*

*Megha Parekh, MD, is an assistant professor in the Department of Anesthesia and Perioperative Care at the University of California, San Francisco, CA.*

*Michael Gropper, MD, PhD, is professor and chair of the Department of Anesthesia and Perioperative Care at the University of California, San Francisco, CA.*

*Jina Sinskey, MD, Joyce Chang, MD, and Megha Parekh, MD, have no conflicts of interest. Michael Gropper, MD, PhD, has received royalties from Elsevier, and his spouse is an officer and shareholder for Kindbody, Inc. (no conflict related to this work).*

## REFERENCES

1. Shanafelt TD, Noseworthy JH. Executive leadership and physician well-being: nine organizational strategies to promote engagement and reduce burnout. *Mayo Clin Proc.* 2017;92:129–146. doi.org/10.1016/j.mayocp.2016.10.004
2. Shanafelt TD, West CP, Sloan JA, et al. Career fit and burnout among academic faculty. *Archives of Internal Medicine.* 2009;169:990–995. doi.org/10.1001/archinternmed.2009.70
3. National Academies of Sciences, Engineering, and Medicine. Taking action against clinician burnout: a systems approach to professional well-being. *The National Academies Press.* 2019. doi.org/10.17226/25521

4. Thornton KC, Sinskey JL, Boscardin CK, Sullivan KR. Design and implementation of an innovative, longitudinal wellness curriculum in an anesthesiology residency program. *A & A Pract.* 2021;15:e01387. doi.org/10.1213/xxa.0000000000001387
5. Infosino A, Ferschl MB. Initial implementation of a combined faculty member and fellow exchange programme. *Med Educ.* 2020;54:460–461. doi.org/10.1111/medu.14103
6. Ferschl MB, Boscardin C, Ravula N, Infosino A. Implementation and assessment of a visiting scholar exchange program in pediatric anesthesiology to promote junior faculty and fellow professional development. *J Educ Perioper Med.* 2021;23:E661. https://pubmed.ncbi.nlm.nih.gov/34104675/
7. Pisaniello MS, Asahina AT, Bacchi S, et al. Effect of medical student debt on mental health, academic performance and specialty choice: a systematic review. *BMJ Open.* 2019;9:e029980. dx.doi.org/10.1136/bmjopen-2019-029980
8. Shanafelt T, Goh J, Sinsky C. The business case for investing in physician well-being. *JAMA Internal Medicine.* 2017;177:1826–1832. doi.org/10.1001/jamainternmed.2017.4340
9. Leiter MP, Maslach C. Six areas of worklife: a model of the organizational context of burnout. *J Health Hum Serv Adm.* 1999;21:472–489.
10. Shapiro DE, Duquette C, Abbott LM, et al. Beyond burnout: a physician wellness hierarchy designed to prioritize interventions at the systems level. *Am J Med.* 2019;132:556–563. doi.org/10.1016/j.amjmed.2018.11.028
11. Sinskey JL, Chang JM, Nicholau D, Gropper MA. (in press). Quality of life improvement: a novel framework and approach to well-being. *Anesthesiol Clin.* 2021 (in press).



## Vision

The vision of the Anesthesia Patient Safety Foundation is to ensure that no one shall be harmed by anesthesia care.

## & Mission

The APSF’s mission is to improve the safety of patients during anesthesia care by:

- Identifying safety initiatives and creating recommendations to implement directly and with partner organizations
- Being a leading voice for anesthesia patient safety worldwide
- Supporting and advancing anesthesia patient safety culture, knowledge, and learning

# APSF Awards 2022 Grant Recipients

by Yan Xiao, PhD

The APSF grant program supports and advances anesthesia patient safety culture, knowledge, and learning, a part of the APSF mission. The program has played an essential role in establishing and enhancing careers of many in conducting safety research and education. Since 1987, the APSF has supported 130 anesthesia professionals with more than \$13.5 million in funding.

The 2020–21 APSF investigator-initiated grant program received 28 letters of intent. The Scientific Evaluation Committee scored and discussed these letters, with the assistance of external statistical reviewers. The top four scoring letters were invited to submit full proposals for final review and were discussed via a hybrid meeting on October 9, 2020. Three proposals were recommended for funding to the APSF Executive Committee and Board of Directors, and all three received unanimous support. This year's recipients were Vesela Kovacheva, MD, PhD, from Harvard Medical School, Stephen Choi, MD, FRCPC, MSc, from the University of Toronto, and Paloma Toledo, MD, MPH, from Northwestern University. The principal investigators of this year's APSF grant provided the following descriptions of their proposed work.



**Vesela Kovacheva, MD, PhD**

Assistant Professor of Anesthesia, Harvard Medical School

Vesela Kovacheva's project is entitled "**Development of Novel Machine Learning Tool to Predict Risk for Severe Maternal Morbidity and Optimize Anesthesiology Resources.**"

**Background:** The United States is the only developed country in which the rates of severe maternal morbidity have been steadily increas-

ing over the past decade—this is an important patient safety priority. Every year in the United States, more than 50,000 women experience severe maternal morbidity, and 700 women die from pregnancy-related conditions.<sup>1</sup> Severe maternal morbidity is highly preventable and considered a "near miss," since without timely treatment or resources it may lead to maternal death.<sup>2</sup> There are significant racial disparities in outcomes, and Black women are up to four times more likely to suffer severe maternal morbidity compared to White women.<sup>3</sup> The risk-adjusted severe maternal morbidity rates can vary up to six times among hospitals, suggesting a large contribution of the quality of care to observed racial disparities in pregnancy-related outcomes.<sup>3</sup> Up to 46% of Black and 33% of White maternal deaths could be prevented by improving the quality of hospital care.<sup>4</sup> However, there is currently no universally utilized or validated severe maternal morbidity prediction tool in clinical obstetric practice. Machine learning tools to combine various clinical risk factors have recently become available. In addition, novel approaches, like explainable artificial intelligence are being developed to aid performance evaluation, un-biasing, and transparency of the decision-making process.

**Aims:** In line with the APSF goals to improve patient safety, we propose to leverage our rich patient database and computational tools to improve maternal outcomes during delivery. We will design machine learning models using approaches like regression, decision tree models, and neural networks. We will select the best performing model in all racial groups and determine the optimal conditions when anesthesiology resources should be mobilized. We will prospectively evaluate the model accuracy and determine blood product crossmatch, utilization, and staffing escalation. Our long-term goal is to develop a high-fidelity, personalized, and fair algorithm to predict the risk of severe maternal morbidity in pregnant women and support the anesthesiology provider in preparing for and managing the highest risk patients.

**Implications:** United States has one of the most advanced health care systems in the world, yet maternal morbidity and mortality are significantly higher than in similarly developed countries. There are significant practice variations across different states and hospital systems. Encouraging evidence-based stratification of high-risk pregnant patients is one of the two most important objectives launched by the Department of Health and Human Services to achieve the goal of 50% reduction in mater-

nal mortality over the next 5 years.<sup>5</sup> Our proposed novel tool will aid identification of parturients at risk for adverse outcomes with the long-term goal of increasing maternal safety during delivery.

## REFERENCES

1. Hoyert DL, Minino AM. Maternal mortality in the United States: changes in coding, publication, and data release, 2018. *Natl Vital Stat Rep.* 2020;69:1–18.
2. American College of Obstetricians and Gynecologists, Society for Maternal-Fetal Medicine. Obstetric care consensus no. 5: severe maternal morbidity: screening and review. *Obstet Gynecol.* 2016;128:e54–60.
3. Howell EA. Reducing disparities in severe maternal morbidity and mortality. *Clin Obstet Gynecol.* 2018;61:387–399.
4. Berg CJ, Harper MA, Atkinson SM, et al. Preventability of pregnancy-related deaths: results of a state-wide review. *Obstet Gynecol.* 2005;106:1228–1234.
5. Healthy women, healthy pregnancies, healthy futures: action plan to improve maternal health in America. U.S. Department of Health and Human Services; 2020.

**Funding:** \$149,998 (January 1, 2022–December 31, 2023). This grant was designated as the APSF/Medtronic Research Award, and was also designated as the APSF Ellison C. Pierce, Jr., MD, Merit Award with \$5000 unrestricted research support.



**Stephen Choi MD, FRCPC, MSc**

Associate Professor, Department of Anesthesia, Sunnybrook Health Sciences Centre, University of Toronto

Dr. Choi's project is entitled "**Redesigning the surgical pathway: optimizing PReOperative assessMent in anesthesia clinic for adult surgical patients (PROMoTE).**"

**Background:** Globally, over 300 million surgeries are performed yearly. Risk stratification and monitoring for cardiorespiratory complications are well established to allow early identification and management. Unfortunately, perioperative neurocognitive

See "2022 Grant Recipients," Next Page



## APSF 2022 Grant Recipients

From “2022 Grant Recipients,” Preceding Page

disorders (PND), which include postoperative delirium (POD) and postoperative neurocognitive disorders (P-NCD) are frequently missed. Approximately 25% of patients suffer from POD and experience excess morbidity and mortality.<sup>1</sup> POD increases health care costs by approximately \$32.9 billion (\$44,291 per patient) annually in the United States.

Importantly, a significant proportion of POD is preventable. Several intraoperative strategies have been trialed with limited success. This includes pharmacotherapeutics, increased regional anesthesia, and anesthetic depth monitoring, each with limited success. Multimodal nonpharmacologic strategies (CHASM from Hospital Elderlife Program [HELP]) are safe and consistently demonstrate large reductions in delirium (OR 0.47).<sup>2</sup> Despite this, implementation is suboptimal, and POD remains stubbornly high, actually increasing between 2003 and 2019.<sup>3</sup>

Barriers to delirium friendly care include institutional pressure to reduce length of stay and being unaware of high-risk individuals. Among the biggest risk factors for POD is any degree of pre-existing cognitive impairment (pre-CI). Pre-CI is common in the surgical population (29%) and is associated with an increased risk of POD (Odds Ratio=2-3).<sup>4</sup> Routine assessment for pre-CI is rare in preoperative clinics. Indeed without systematic objective screening pre-CI is missed. A recent study of 215 preoperative patients identified only 2 with pre-CI during routine assessment, yet 121 had pre-CI when screened with simple cognitive screening.<sup>5</sup>

Individuals at high risk for POD (pre-CI), a common complication with major negative consequences, are not identified and are not managed with a known, safe, and effective intervention (CHASM from HELP). The perioperative team (anesthesia professionals, surgeons, nurses) are not ignorant of best practices, nonetheless implementation is suboptimal. Importantly, awareness of high-risk status can positively impact behavior. Evidence comes from the dementia realm where knowledge of impaired cognitive status led to multiple increased interventions from health care workers including additional assessments and referral.

**Aims:** This project aims to reduce POD incidence and severity. By proactively identifying patients with pre-CI, a comprehensive pro-

gram can target these high-risk individuals. The program will engage patients, caregivers, perioperative physicians, and nursing/allied health staff to utilize delirium friendly practices (e.g., minimize benzodiazepines, utilize regional analgesia and anesthetic depth monitoring where possible, minimize opioids, reduce urinary catheter usage, and engage in educational sessions to reinforce CHASM). Additionally flagging high-risk individuals to all team members will promote adherence to POD friendly best practices. This comprehensive approach, from identification to collaborative care, will reduce the incidence of POD in surgical patients. This will be prospectively assessed with a two-phase, observational study (pre/post implementation).

**Implications:** POD continues to be a problem. It has effects on morbidity, mortality, and quality of life beyond the immediate perioperative period. A large proportion of the population presenting for surgery is elderly and will increase with demographics. Without a concerted effort to address POD, the problem will only get worse. Introducing a comprehensive program in high-risk POD patients that combines multiple aspects of POD friendly care—patient/family engagement, perioperative team awareness and application of best practices—is necessary. However, without identifying high-risk patients before the onset of POD, care that will help patients cannot be initiated. Identification will facilitate awareness and the opportunity to target those most at risk.

### REFERENCES

1. Evered L, Silbert B, Knopman DS, et al. Recommendations for the nomenclature of cognitive change associated with anaesthesia and surgery-2018. *Anesthesiology*. 2018;129:872–879.
2. Hshieh TT, Yang T, Gartaganis SL, et al. Hospital elder life program: systematic review and meta-analysis of effectiveness. *Am J Geriatr Psychiatry*. 2018;26:1015–1033.
3. Silva AR, Regueira P, Albuquerque E, et al. Estimates of geriatric delirium frequency in noncardiac surgeries and its evaluation across the years: a systematic review and meta-analysis. *J Am Med Dir Assoc*. 2021;22:613–620 e619.
4. Greaves D, Psaltis PJ, Ross TJ, et al. Cognitive outcomes following coronary artery bypass grafting: A systematic review and meta-analysis of 91,829 patients. *Int J Cardiol*. 2019;289:43–49.
5. Smith NA, Yeow YY. Use of the Montreal Cognitive Assessment test to investigate the prevalence of mild cognitive impairment in the elderly elective surgical population. *Anaesth Intensive Care*. 2016;44:581–586.

**Funding:** \$150,000 (January 1, 2022–December 31, 2023). The grant was designated as the APSF/ American Society of Anesthesiologists (ASA) President’s Research Award.



**Paloma Toledo, MD, MPH**

*Assistant Professor, Department of Anesthesiology, Northwestern University*

Paloma Toledo's project is entitled “**Iron Deficiency Anemia: Developing and Implementing an Intervention to Treat this Preventable Cause of Maternal Morbidity.**”

**Background:** Postpartum hemorrhage (PPH) complicates 4–6% of all deliveries in the US and is a leading cause of maternal morbidity and mortality worldwide.<sup>1</sup> Hemorrhage-related morbidity includes blood transfusions, complications from blood transfusions, potential end-organ damage to the patient (e.g., renal injury), and loss of future fertility if a hysterectomy is performed. Poor outcomes from PPH are highly preventable and amenable to safety interventions.<sup>2</sup> This prevention is possible through patient safety interventions such as clear guidelines, readiness, and effective emergency response. To date, many efforts have been focused on improving the in-hospital management of PPH, but few have focused on identifying and addressing modifiable risk factors prior to delivery. Iron deficiency anemia (IDA) complicates greater than 20% of all pregnancies, and is easily correctable.<sup>3</sup> Early identification and treatment of anemia may prevent or mitigate adverse outcomes, such as depression, fatigue, or the need for transfusion should an anemic woman hemorrhage.<sup>3,4</sup>

Despite the frequency of iron deficiency anemia in the pregnant population, treatment protocols to guide peripartum anemia management are scarce. The American College of Obstetrician and Gynecologists recommends pregnant women be screened for IDA, but there is little guidance regarding the timing of

See “2022 Grant Recipients,” Next Page

## 2022 APSF Grant Recipients

From “2022 Grant Recipients,” Preceding Page this screening, and there is even less consensus on how to manage patients diagnosed with IDA (oral vs intravenous iron therapy).<sup>5</sup> Oral iron therapy, while easy to administer and low-cost, is poorly tolerated due to side effects. Intravenous iron (IV) infusions are effective, and well tolerated, but have not been widely implemented in obstetric practice.

**Aims:** As anemic women are more likely to be harmed if they hemorrhage, it is important to identify barriers to treatment and create an anemia management algorithm. Using qualitative methodology, we will identify patient and provider awareness of the significance of maternal anemia, awareness of treatment options, and barriers to treatment. We will then convene a multidisciplinary expert panel to design a prenatal anemia management protocol and optimal workflows. We will then implement the anemia management protocol at our

institution and evaluate the proportion of women who have received treatment for their anemia, as well as measure the impact on maternal outcomes.

**Implications:** While postpartum hemorrhage (PPH) is not preventable, poor outcomes, particularly maternal morbidity and mortality from hemorrhage are highly preventable. Anemia is easily recognized and treated, therefore, an ideal safety intervention to improve patient outcomes. This project will improve patient safety through systems-level improvements in patient outcomes and prevention of clinical deterioration in the event of a hemorrhage. We anticipate that this protocol will be most influential in resource-limited environments, where treatment options for postpartum hemorrhage are scant and the potential for maternal harm is great.

### REFERENCES

1. Berg CJ, Callaghan WM, Syverson C, Henderson Z. Pregnancy-related mortality in the United States, 1998 to 2005. *Obstet Gynecol.* 2010;116:1302–1309.
2. Berg CJ, Harper MA, Atkinson SM, et al. Preventability of pregnancy-related deaths: results of a state-wide review. *Obstet Gynecol.* 2005;106:1228–1234.
3. Drukker L, Hants Y, Farkash R, et al. Iron deficiency anemia at admission for labor and delivery is associated with an increased risk for Cesarean section and adverse maternal and neonatal outcomes. *Transfusion.* 2015;55:2799–2806.
4. VanderMeulen H, Strauss R, Lin Y, et al. The contribution of iron deficiency to the risk of peripartum transfusion: a retrospective case control study. *BMC Pregnancy Childbirth.* 2020;20:196.
5. American College of Obstetricians and Gynecologists: ACOG Practice Bulletin No. 95: anemia in pregnancy. *Obstet Gynecol.* 2008;112:201–207.

**Funding:** \$149,592 (January 1, 2022–December 31, 2023).

Yan Xiao, PhD, is a professor at the University of Texas at Arlington College of Nursing and Health Innovation, and the chair of the APSF's Scientific Evaluation Committee.



## Join the #APSF Crowd!

Donate now at <https://apsf.org/FUND>



The Anesthesia Patient Safety Foundation is launching our first-ever crowdfunding initiative, defined as raising small amounts of money from a large number of people.

**Just \$15 can go a long way to reach our goals.**

Help support the vision that “no one shall be harmed by anesthesia care.”

# Anesthesia Patient Safety Foundation

Founding Patron (\$340,000)  
American Society of Anesthesiologists (asahq.org)



## 2022 Corporate Advisory Council Members (current as of January 1, 2022)

### Platinum (\$50,000)



### Gold (\$30,000)

### Silver (\$10,000)

Dräger Heron Therapeutics Pall Corporation Sensime

Special recognition and thank you to Medtronic for their support and funding of the APSF/Medtronic Patient Safety Research Grant (\$150,000); and Merck for their educational grant.

For more information about how your organization can support the APSF mission and participate in the 2022 Corporate Advisory Council, go to: [apsf.org](https://apsf.org) or contact Sara Moser at: [moser@apsf.org](mailto:moser@apsf.org).

## Community Donors (includes Specialty Organizations, Anesthesia Groups, ASA State Component Societies, and Individuals)

### Specialty Organizations \$2,000 to \$4,999

The Academy of Anesthesiology  
Intersurgical, Inc.

### Anesthesia Groups \$15,000 and Higher

US Anesthesia Partners  
\$5,000 to \$14,999

North American Partners in Anesthesia  
NorthStar Anesthesia  
PhyMed  
TeamHealth

\$2,000 to \$4,999  
Madison Anesthesiology Consultants, LLP

### \$750 to \$1,999

Anesthesia Associates of Columbus, PA  
Anesthesia Consultants of Athens, LLP (in honor of Albert Santora, MD)  
NorthShore University Health System CRNAs (in honor of Dr. Joseph Szokol)  
Society for Pediatric Anesthesia

### \$200 to \$749

Association of Anesthesiologist Assistant Education Program

### ASA State Component Societies \$5,000 to \$14,999

Indiana Society of Anesthesiologists  
Minnesota Society of Anesthesiologists  
Tennessee Society of Anesthesiologists  
\$2,000 to \$4,999  
California Society of Anesthesiologists

Connecticut State Society of Anesthesiologists  
Massachusetts Society of Anesthesiologists  
Michigan Society of Anesthesiologists  
Washington State Society of Anesthesiologists  
Wisconsin Society of Anesthesiologists  
\$750 to \$1,999  
Arizona Society of Anesthesiologists  
Arkansas Society of Anesthesiologists  
Georgia Society of Anesthesiologists  
Illinois Society of Anesthesiologists  
Iowa Society of Anesthesiologists  
Kentucky Society of Anesthesiologists  
Nebraska Society of Anesthesiologists, Inc.  
Ohio Society of Anesthesiologists  
Pennsylvania Society of Anesthesiologists  
Rhode Island Society of Anesthesiologists  
Society for Pediatric Anesthesia  
South Carolina Society of Anesthesiologists

\$200 to \$749  
Colorado Society of Anesthesiologists  
Mississippi Society of Anesthesiologists  
New Jersey State Society of Anesthesiologists  
Virginia Society of Anesthesiologists

### Individuals

#### \$15,000 and Higher

Steven J. Barker, MD, PhD  
James J. Lamberg, DO, FASA  
Mary Ellen and Mark A. Warner

#### \$5,000 to \$14,999

Mrs. Isabel Amone (in honor of Lawrence J. Amone, MD, FACA)  
Dr. Eric and Marjorie Ho  
Thomas L. Warren, MD (in memory of Ursula Dyer, MD)

#### \$2,000 to \$4,999

Robert Caplan, MD (in honor of Mark Warner, MD)  
Fred Cheney, MD  
Jeffrey B. Cooper, PhD  
Jeff Feldman, MD  
Steven Greenberg, MD  
Joshua Lea, CRNA (in honor of Maria van Pelt, PhD, CRNA)  
Patty Mullen Reilly, CRNA  
Drs. Ximena and Daniel Sessler  
Brian J. Thomas, JD  
Joyce Wahr, MD

#### \$750 to \$1,999

Donald E. Arnold, MD, FASA  
Douglas R. Bacon, MD, MA (in honor of Mark Warner)  
Doug and Jen Bartlett  
Casey Blitt, MD  
Daniel J. Cole, MD  
Thomas Ebert, MD  
James and Patricia Eisenach  
David M. Gaba, MD, and Deanna Mann  
Drs. James and Lisa Grant  
Alexander Hannenberg, MD (in honor of Mark A. Warner)  
Rebecca L. Johnson, M.D.  
Catherine Kuhn, MD (in honor of Stephen Klein, MD, and Meredith Muncy, CRNA)  
Meghan Lane-Fall, MD, MSHPE  
Cynthia A. Lien  
Emily Methangkool, MD, MPH  
Mark C. Norris, MD (in memory of Barbara Leighton, MD)

May Pian-Smith, MD, MS (in honor of Jeffrey Cooper, PhD)  
Elizabeth Rebello, MD  
Stephen Skahen, MD  
Marjorie Stiegler, MD  
Dr. Donald C. Tyler

#### \$200 to \$749

Arnoley Abcejo, MD  
Rita Agarwal MD, FAAP, FASA  
Aalok Agarwala, MD, MBA  
Shane Angus, AA-C  
John (JW) Beard, MD  
David and Samantha Bernstein (in honor of Jeff Cooper)  
Bonnie and John Burkert  
Matthew W. Caldwell  
Michael Caldwell  
Alexis Carmer  
Alexander Chaikin  
Marlene V. Chua, MD  
Heather Ann Columbano  
Jeremy Cook, MD  
Kenneth Cummings, MD  
John K. DesMarteau, MD  
Karen B. Domino, MD  
Teresa Donat  
Christine Doyle  
Elizabeth Drum  
Steven B. Edelstein, MD, FASA  
Mike Edens and Katie Megan  
Mary Ann and Jan Ehrenwerth, MD (in memory of Charles Cowles, MD)  
James English  
Thomas R Farrell, MD  
John Fiadjo (in memory of Rhonda Alexis)  
Carlos R Gracia, MD, and Shauna O'Neill Gracia (in memory of Andrew A. Knight, MD)  
James S. Gessner, MD  
Ian J. Gilmour, MD  
Linda K. Groah  
Allen N. Gustin, MD

Eugenie Heitmiller  
Steven K. Howard, MD  
Jeffrey Huang, MD  
Ken Johnson, MD  
Robert E. Johnstone, MD  
Ann Kinsey, CRNA  
Goral Krishna, MD  
Laurence A. Lang, MD  
Della M. Lin, MD  
Elizabeth Malinzak  
Edwin Mathews, MD  
Stacey Maxwell  
Gregory McComas, MD  
James P. McMichael, MD (in memory of Howard Zauder, MD)  
William McNiece, MD  
Jonathan Metry  
Michael D. Miller, MD  
Sara Moser  
Rashmi Mueller  
Drs. Michael and Georgia Olympio  
Ducu Onisei MD  
Dr. Fredrick Orkin  
Frank Overdyk, MD  
Michele Pelot, MD  
Lee S. Perrin, MD  
Janet Pittman, MD and Esther McKenzie, MD (in memory and honor of Aharon Guterman, MD)  
Paul Pomerantz  
Cathleen Price  
Richard Prielipp, MD  
Sheila Riazzi  
Dru Riddle, CRNA  
Drew Rodgers, MD (in honor of Stan Strickland, MD)  
David Rotberg, MD  
Steven Sanford, JD  
Scott Segal  
Adam Setren, MD  
David A. Shapiro, MD, and Sharon L. Wheatley (in memory of Andrew Knight, MD)

Emily Sharpe, MD  
Simanonok Charitable Giving Fund  
Ty A. Slatton, MD, FASA  
Michael D. Sparkuhl, MD, FACS  
Brad Steenwyk  
Robert K. Stoelting, MD  
James F. Szocik, MD  
Ellen and Butch Thomas  
Laurence and Lynn Torsher  
James A. Totten, M.D.  
Andrea Vannucci, MD  
Matthew B. Weinger, MD  
Andrew Weisinger  
Anne and Jim West, MD  
Laura E. Whalen, CRNA  
Paul and Elizabeth Wheeler (in memory of Andrew Knight, MD)  
G. Edwin Wilson, MD  
Cynthia A Wong (in honor of Jeffrey Cooper)  
Shannon and Yan Xiao  
Ziad Yafi

### Legacy Society <https://www.apsf.org/donate/legacy-society/>

Dan and Cristine Cole  
Karma and Jeffrey Cooper  
Dr. John H. and Mrs. Marsha Eichhorn  
Burton A. Dole, Jr.  
David Gaba, MD, and Deanna Mann  
Drs. Alex and Carol Hannenberg  
Drs. Joy L. Hawkins and Randall M. Clark  
Dr. Eric and Marjorie Ho  
Drs. Michael and Georgia Olympio  
Dr. Ephraim S. (Rick) and Eileen Siker  
Robert K. Stoelting, MD  
Mary Ellen and Mark Warner  
Drs. Susan and Don Watson  
Matthew B. Weinger, MD, and Lisa Price

Note: Donations are always welcome. Donate online (<https://www.apsf.org/donate/>) or mail to APSF, P.O. Box 6668, Rochester, MN 55903. (Donor list current as of December 1, 2020–November 30, 2021.)



# Challenges and Solutions for Reducing Infection Risks When Accessing Vascular Catheters

by Elliott S. Greene, MD

## INTRODUCTION

In U.S. acute care hospitals, 3.2% of patients develop one or more health care-associated infections (HAIs) resulting in increased patient morbidity, mortality, duration of hospitalization, and health care costs.<sup>1</sup> Catheter-related bloodstream infections (CRBSIs) are the most common etiology of HAI and these can occur with central as well as peripheral intravascular catheters.<sup>1</sup> Each year in the U.S., there are approximately 250,000 CRBSIs from short- and long-term intravascular catheters resulting in significant morbidity, including sepsis, other complications, and mortality.<sup>1</sup> In 2014, U.S. acute care hospitals had over 31,000 patients with central-line-associated bloodstream infections (CLABSIs), with an estimated annual cost of \$0.6–2.7 billion and a mortality rate of 12–25%.<sup>1</sup> CLABSI rates have generally ranged from 1.1–2.5/1000 catheter-days, and each CLABSI on average increases the hospital stay by 10.4 days and adds more than \$45,000 in costs.<sup>1</sup> In a review of short-term peripheral intravenous catheter (PIVC) CRBSIs from 1980 to 2106, the infection incidence (not reported per 1000 catheter-days) was 1.8 infections/1000 catheters. The arterial catheter CRBSI rate in a 2014 study was 1.26/1000 catheter-days, with the CRBSI risk for the femoral site 1.9 times higher than that of the radial site.<sup>1</sup> Microbial contamination of intravascular catheters may occur from either 1) an extraluminal route involving distal migration from the insertion site or 2) intraluminal contamination, which can occur when accessing and using these catheters, with less frequent

sources from hematogenous spread or contaminated infusate.

Accessing vascular catheters is routine while providing anesthesia and other patient care, but are health care professionals using optimal methods to reduce the risk of vascular catheter access-related HAIs? If hand hygiene and aseptic technique are not used when accessing vascular catheters, intraluminal contamination of injection ports (e.g., open lumen stopcocks [OLSs]) and disinfectable needleless closed connectors (DNCCs) with microbial pathogens may occur that may lead to CRBSIs and other HAIs.<sup>1,3</sup> Unfortunately, low hand hygiene compliance rates have been reported for anesthesia professionals with ranges from 2.9% to 18%.<sup>1,4</sup> Syringes and infusions can become contaminated during medication preparation and clinical use with resultant injection of contaminated contents into the bloodstream as well as contamination of access ports.<sup>1,2,5-7</sup> Increased use of manufacturer or pharmacy-prepared medication syringes and infusions is recommended by the Anesthesia Patient Safety Foundation, the Association for Professionals in Infection Control and Epidemiology, and the Institute for Safe Medication Practices to decrease contamination and medication errors during preparation and administration of medications and fluids.<sup>1,2,5,6</sup> The Centers for Disease Control and Prevention also provides recommendations for Safe Injection Practices.<sup>7</sup> This article will compare and contrast contamination and infection risks related to the use of OLSs vs.

DNCCs, and discuss recommendations as well as unresolved issues concerning DNCC disinfection.

## CONTAMINATION AND INFECTION RISKS OF OLSs AND DISINFECTED DNCCs

OLSs are commonly used in the practice of anesthesia; however, contamination of intraluminal surfaces may occur in up to 32% to 38% of anesthesia cases.<sup>8,9</sup> Neither a 70% isopropyl alcohol (IPA) pad, nor a port-scrub device effectively disinfects an OLS.<sup>3,10</sup> An OLS is prone to contamination due to its design with a removable cap which exposes intraluminal surfaces (Figure 1). While over 50% of DNCCs are contaminated with bacteria on their injection surfaces prior to appropriate disinfection,<sup>11,12</sup> a DNCC's injection surface can be disinfected with a high level of effectiveness by scrubbing with an alcohol-containing disinfectant pad or using an IPA cap (Figure 2).<sup>1,3,11-17</sup> In a recent critical review of injection ports, 8 of 10 studies had significantly lower rates of intraluminal contamination with disinfected DNCCs compared to OLSs, and 2 of 7 studies had significantly decreased rates of CLABSIs or CRBSIs with disinfected DNCCs compared to OLSs (some studies evaluated both contamination rates and infection rates, while other studies evaluated only a single outcome: either contamination rates or infection rates).<sup>1</sup> When examining the subgroup of these studies where both OLSs and DNCCs were disinfected before access, 7 of 9 studies found significantly lower rates of intraluminal contamination with DNCCs compared to OLSs, and 1 of 4 studies had a significantly lower rate of CLABSIs with DNCCs.<sup>1</sup> No studies found OLSs were beneficial compared to disinfected DNCCs (See Table 1).<sup>1</sup>

## MICROBIAL INJECTION AND BIOFILM

Failure to disinfect DNCCs before access, or contamination of OLSs during clinical use, can lead to intraluminal contamination,<sup>1,15</sup> resulting in biofilm formation (micro-organisms embedded in an extracellular glyco-calyx matrix) on the catheter's surfaces resulting in an increased risk of HAIs.<sup>18,19</sup>

Even a single omission of DNCC disinfection before access can result in the formation of biofilm.<sup>19</sup> Unfortunately, DNCC disinfection compliance (including hand hygiene and aseptic technique) has been challenging for health care professionals.<sup>1,15,20</sup> Although the current literature does not fully explain biofilm's defense mechanisms against antimicrobial agents, exopolysaccharides impair antibiotics from penetrating the biofilm matrix to reach bacteria in the biofilm.<sup>21</sup>

See "Vascular Catheters," Next Page

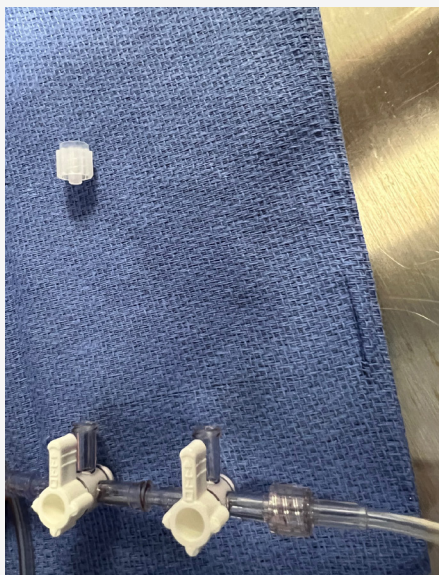

Figure 1: Open Lumen Stopcock (OLS).

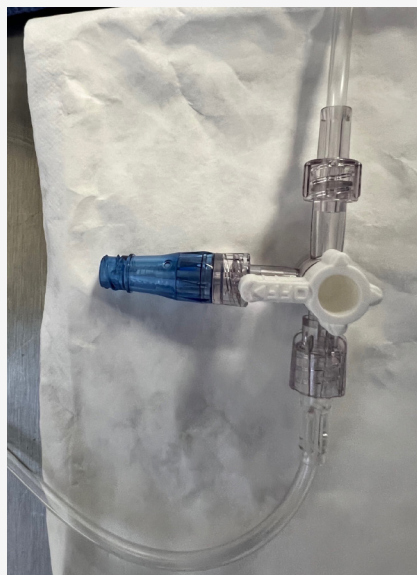

Figure 2: Disinfectable Needleless Closed Connector (DNCC).

# Failure to Disinfect Connectors can Lead to Intraluminal Contamination

From “Vascular Catheters,” Preceding Page

Biofilm may also be resistant to the host’s immune system.<sup>22,23</sup> Thus, biofilm can be a source of bacteremia and chronic infections.<sup>21-23</sup> While *in-vitro* studies suggest that leukocytes are able to effectively penetrate biofilms, animal studies indicate that biofilm formation results in an “evasion” of the host’s immune response from a “pro-inflammatory, bactericidal response” towards an “anti-inflammatory, pro-fibrotic response.”<sup>22</sup> Biofilm formation on surfaces of catheters and other implanted medical devices thus protects the bacteria which encourages the persistence of infection.<sup>22</sup>

An additional mechanism of microbial injection may explain the association of OLS and DNCC contamination with subsequent increased risk of HAIs.<sup>14</sup> Inadvertent direct microbial injection into the bloodstream may occur during vascular access via a contaminated OLS or failure to disinfect a DNCC injection surface before injection. Inadvertent direct microbial injection may also occur if a contaminated syringe or infusate is used.<sup>1,2,5-7</sup> In an *ex-vivo* randomized control trial (RCT), conducted during concurrent clinical anesthesia, approximately 10,000 colony forming units of bacteria entered the test circuit per injection when DNCCs or OLSs were not disinfected before access.<sup>14</sup> In this study, the incidence of inadvertent bacterial injection was significantly lower when using disinfected DNCC-stopcocks (70% alcohol [method unspecified] with 30 seconds drying) compared to OLSs or DNCC-stopcocks without disinfection.<sup>14</sup>

## RECENT RECOMMENDATIONS FROM THE SOCIETY FOR HEALTHCARE EPIDEMIOLOGY OF AMERICA

The Society for Healthcare Epidemiology of America (SHEA) recently published guidelines for infection prevention in the anesthesia work environment.<sup>15</sup> SHEA recommends using disinfected DNCCs on stopcocks for injecting medications as the preferred choice for clinician use rather than using OLSs.<sup>24,25</sup> SHEA also noted that “stopcocks on pressure transducers are periodically opened to air to calibrate the transducer” and that “these stopcocks may reasonably be covered with sterile caps rather than needleless injection ports” (DNCCs), but did not comment on a method to maintain intraluminal sterility when the transducer is opened to air.<sup>25</sup> It is important that stopcocks used for zeroing pressure transducers maintain intraluminal sterility. While some transducers include a cap with a “small” hole (much smaller than the lumen) which can eliminate the need for cap removal during zeroing, it is unknown whether intraluminal sterility is maintained since this “small” lumen is continuously open to the environment. Furthermore, if this cap is not bonded to the stopcock, the provider might circumvent any potential advantage of this cap’s design by removing the cap during zeroing, thus fully

**Table 1: Comparison of Disinfectable Needleless Closed Connectors (DNCCs) to Open Lumen Stopcocks (OLSs)**

Disinfectable Needleless Closed Connectors	Open Lumen Stopcocks
1. Lower rates of intraluminal contamination with disinfected DNCCs compared to OLSs	1. Contamination of intraluminal surfaces may occur in up to 38% of anesthesia cases
2. Lower rates of HAIs for disinfected DNCCs compared to OLSs	2. Intraluminal surfaces are prone to contamination due to OLS's design with a removable cap which exposes intraluminal surfaces of the cap and OLS lumen
3. Can be disinfected with a high level of effectiveness by scrubbing with an alcohol-containing disinfectant pad or using an IPA cap	3. Neither an IPA pad nor a port-scrub device effectively disinfects an OLS
4. SHEA recommends that a stopcock should be accessed via a disinfected DNCC on the stopcock instead of using an OLS	4. No current studies have found OLSs beneficial compared to disinfected DNCCs
5. Compliance with DNCC disinfection immediately before access is critical	5. Using a nondisinfected DNCC or an OLS increases the risk of intraluminal contamination and HAIs compared to using a disinfected DNCC
6. Unfortunately, there is limited manufacturer product availability of DNCC-stopcocks for either intravenous or arterial access	

Abbreviations: DNCC-stopcock, stopcock with a DNCC attached (preferably bonded) to the injection lumen; HAIs, health care-associated infections; IPA, 70% isopropyl alcohol; SHEA, Society for Healthcare Epidemiology of America

exposing the intraluminal surfaces to potential environmental contamination. A stopcock with a bacterial filter bonded to the zeroing lumen may serve as an alternative option.

DNCCs would be when OLS are restricted to use on sterile field related-procedures.<sup>1</sup>

## ACCESSING VASCULAR CATHETERS VIA DISINFECTED DNCCs

The current literature supports that disinfected DNCCs should be used instead of OLSs based on the following premises: the documented overall lower contamination and infection risks of disinfected DNCCs compared to OLSs as discussed above (Table 1) and the recent SHEA recommendations that “stopcocks used for injecting drugs should ideally be closed with needleless injection ports.”<sup>25</sup> To reduce infection-related patient risk, vascular catheters used for medication or fluid administration, or blood withdrawal, should be routinely accessed via either disinfected DNCCs (e.g., in intravenous [IV] tubing sets) or via disinfected DNCC-stopcocks. Compliance with disinfection is essential. For DNCC-stopcocks, the DNCC should preferably be bonded to the stopcock injection lumen to eliminate removal and bypassing the DNCC.<sup>1</sup> While the recent SHEA recommendations<sup>25</sup> do not specifically address using DNCCs to obtain blood samples from arterial pressure tubing, current studies<sup>1</sup> support that blood samples from arterial tubing sets be obtained via disinfected DNCC-stopcocks instead of OLSs. The only clinical application where OLSs would not have a greater contamination or infection risk compared to disinfected

## LIMITED MANUFACTURER AVAILABILITY OF DNCC-STOPCOCKS

Presently, IV and arterial transducer tubing sets do not typically come with DNCC-stopcocks.<sup>1</sup> Manufacturers should supply IV and arterial transducer tubing sets with DNCC-stopcocks instead of OLSs and there should be DNCC-stopcocks made available as single packaged items. There are several reasons why DNCC-stopcocks are not routinely included in tubing sets including lack of clinician and manufacturer awareness of DNCC superiority, inertia in changing existing practice patterns, and increased cost. Nevertheless, the need to improve safety through adoption of DNCCs is inevitable and the increased cost should not be a barrier. For example, sharps injury prevention safety devices cost more than nonsafety devices, but they are now utilized as standard safety requirements.<sup>1,26</sup>

## DISINFECTION METHOD AND TYPE OF DISINFECTANT

The type of disinfectant and disinfection method used on DNCCs are critical factors to maximize the disinfectant’s effectiveness and reduce unwanted HAIs.<sup>1,27</sup> The variations in results of several selected *in-vitro* and clinical studies highlight the difficulties in determining

See “Vascular Catheters,” Next Page

# Society For Health Care Epidemiology of America Recommends Using Disinfected Needleless Closed Connectors

From “Vascular Catheters,” Preceding Page

definitive disinfection recommendations (Table 2). Unsurprisingly, a consensus is lacking among experts concerning the recommended disinfectant, the disinfection method (e.g., scrub vs. “clean”), disinfection duration and drying time, and whether to use IPA caps (see Table 3).<sup>1</sup> SHEA recommends DNCCs should be disinfected immediately before each access or before a rapid series of injections, such as during anesthesia induction, either by scrubbing (a duration was not specified) with an alcohol-containing disinfectant pad (e.g., IPA or chlorhexidine gluconate [CHG]/IPA), or appropriately utilizing an IPA cap.<sup>1,15</sup> Numerous guidelines<sup>1</sup> recommend scrubbing with an alcohol-containing disinfectant; however, the recommended scrubbing durations vary from ≥ 5 to ≥ 15 seconds (Table 3).<sup>31-33</sup> Since compliance

with longer scrub durations is low,<sup>15</sup> additional research should identify the minimally effective scrub duration.<sup>1</sup> In addition, randomized trials are needed to compare various methods and disinfectants used, since suboptimal DNCC disinfection techniques may increase the risk of HAIs. Further complicating the issue is that the infection risk of disinfected DNCCs may also be related to a variety of injection surface topographies and other design features found in various DNCCs, which can influence disinfection efficacy.<sup>12,13,27,35</sup>

### DISINFECTANT DRYING TIME

A recent study suggested that the disinfectant used on DNCCs should dry before access to reduce the microbial load and its potential for entering the bloodstream.<sup>36</sup> Disinfectant drying times vary after scrubbing DNCCs: IPA

dries in 5 seconds and CHG/IPA dries in 20 seconds, but povidone-iodine is not dry after 6 minutes.<sup>36</sup> However, only a few national and international guidelines mention a need for disinfectant drying (Table 3).<sup>1</sup> Unfortunately, only some clinical and *in-vitro* studies state the drying time after DNCC disinfection, and none compared the effect of various drying times, or no drying at all, on disinfection efficacy.<sup>1</sup> Of the 21 studies evaluating DNCC disinfection assessed in a recent critical review, one study specified a 5-second drying time, 10 studies used ≥ 30 seconds drying, and 10 studies did not specify whether drying was used or not.<sup>1</sup> Further trials need to address the optimal drying time in the perioperative setting so that health care professionals have clarity on how to reduce infection risk.

See “Vascular Catheters,” Next Page

**Table 2: <sup>a,b</sup>Selected 1) *In-Vitro* Studies of Disinfection of Contaminated DNCC Surfaces, and 2) Clinical Studies of DNCC Disinfection**

<i>In-Vitro</i> Studies	Year	Inoculant	Disinfectant, Method, Scrub Time	Drying Time	DNCC Microbial Contamination After Disinfection
Rupp, et al. <sup>11</sup>	2012	10 <sup>3</sup> –10 <sup>5</sup> or 10 <sup>8</sup> CFU <i>S. Epidermidis</i>	IPA “Scrubbed vigorously” 5, 10, 15, 30 seconds.	5 seconds	10 <sup>3</sup> –10 <sup>5</sup> CFU: ≥5 seconds: all sterile 10 <sup>8</sup> CFU: 5 seconds: 20% minimal growth 10 <sup>8</sup> CFU: ≥10 seconds: all sterile
Casey, et al. <sup>13</sup>	2015	103 CFU <i>Staphylococcus aureus</i>	IPA: “firmly applied... and rotated” 5, 15 seconds. Eight different types of DNCCs evaluated.	30 seconds	For some types of DNCCs 5 seconds adequate, For others 15 seconds was inadequate. Overall no significant difference in bacterial growth rate between 5 and 15 seconds groups.
Flynn, et al. <sup>28</sup>	2017	0.5 x 10 <sup>6</sup> CFU <i>Staphylococcus aureus</i> <i>S. Epidermidis</i> <i>Pseudomonas aeruginosa</i> <i>Candida albicans</i>	IPA or 2% CHG/IPA: “scrubbing” 5, 15, 30 seconds. IPA cap on 5 minutes. Half (324/648) of DNCCs were “precoated” with sterile human serum before bacterial inoculation to simulate blood draws or transfusion.	30 seconds	IPA 5 > IPA 15 > IPA 30 > IPA cap > CHG/IPA 5 > CHG/IPA 15 > CHG/IPA 30 Serum “precoating” decreased microbial reduction > 50% “results suggest [DNCCs] are more difficult to decontaminate” after blood draws or transfusion (Flynn, et al.) due to residual organic matter
Clinical Studies	Year	Catheter	Disinfectant, Method, Scrub Time	Drying Time	DNCC Microbial Contamination After Disinfection
Rupp, et al. <sup>11</sup>	2012	Central venous	IPA: “Vigorous scrubbing” 0, 5, 10, 15, 30 seconds. Total of 363 DNCCs evaluated. DNCC injection surface cultured.	5 seconds	Baseline (0 seconds): 66.7% (58/87) of DNCCs were contaminated. 5 seconds disinfection: 1.4% (1/71) DNCCs had positive culture; 5, 10, 15 and 30 seconds: all similar results (p = 0.9).
<sup>c</sup> Slater, et al. <sup>12</sup>	2020	PIVC	IPA or 2% CHG/IPA: “scrubbed” 5, 10 or 15 seconds. Total of 300 DNCCs evaluated. DNCC injection surface cultured.	30 seconds	Baseline: 51% (153/300) of DNCCs contaminated. After disinfection: 2% (3/153) contaminated for all groups combined. No significant differences in microbial growth between groups for either disinfectant p = 0.62, or duration p = 0.21 15 Sec: not effective for 2 DNCCs. 20/153 DNCCs had “heavy” contamination (>15 CFU): After disinfection using IPA for 15 seconds: 5% (1/20) still contaminated.

Abbreviations: CFU, colony forming units bacteria/ml inoculant; CHG, chlorhexidine gluconate; DNCCs, disinfectable needleless closed connectors; IPA, 70% isopropyl alcohol; PIVC, peripheral intravenous catheter.

<sup>a</sup> for additional studies see reference Greene<sup>1</sup>

<sup>b</sup> items in quotations are the terminology used in each reference

<sup>c</sup> first clinical RCT of PIVC DNCC disinfection



## Lower Rates of Intraluminal Contamination with Disinfectable Needleless Connectors vs. Open Lumen Stockcocks

From “Vascular Catheters,” Preceding Page

### IS INJECTING DISINFECTANT INTO A DNCC HAZARDOUS?

A recent study recommended the DNCC should dry before access to avoid injecting disinfectant.<sup>36</sup> An unanswered question is whether injecting some disinfectant into a DNCC is hazardous. This is of great concern since IPA is mainly metabolized to acetone, which is toxic.<sup>16,37,38</sup> Two *in-vitro* studies compared DNCCs scrubbed with either IPA followed by 15 seconds of drying<sup>37</sup> or with CHG/ethanol with 30 seconds of drying time,<sup>38</sup> followed by saline injections. These studies suggested that alcohol levels in the test circuit fluids were either undetectable<sup>37</sup> or “low”<sup>38</sup> (maximum µg per *in-vitro* injection was < 8% of what would produce the estimated toxic blood concentration threshold in neonates, defined as greater than 0.25 mg/ml). Studies on potential IV injection of alcohol or CHG via DNCCs before disinfectant drying are limited in the current literature and therefore, further studies are needed.

### IPA CAPS

Several national and international recommendations include the option of using IPA caps on DNCCs since they provide passive disinfection, eliminate manual scrubbing (after a minimum contact time), provide a visible indicator of disinfection, provide a contamination barrier, and may increase disinfection compliance compared to manual disinfection.<sup>115,17,39</sup> IPA cap use requires at least a minimum contact duration on the DNCC before access (manual



scrubbing is needed for shorter durations), allowing the disinfectant to dry before access, and discarding the cap after each single use. A recent “pilot” RCT found no significant differences in CLABSI rates in adults comparing scrubbing with either IPA or CHG/IPA, or using IPA caps.<sup>27</sup> Although the 2019 SHEA recommendations<sup>15</sup> referred to using IPA caps as a “best practice,” this 2021 “pilot” study suggests that larger more definitive studies should be performed.<sup>27</sup> Two *in-vitro* studies cautioned against using IPA caps in neonates because injection of saline after IPA cap removal resulted in “significant” levels of IPA in the test circuit fluids.<sup>16,37,38</sup> One study found that significant IPA levels in the test circuit fluids occurred after 24 hours of IPA cap use, with even higher IPA levels when the DNCCs were exposed to the IPA caps for 7 days.<sup>38</sup> The finding that IPA was injected into the test cir-

cuit was also problematic since in one study after IPA cap removal, the DNCC was allowed to dry for 30 seconds before injection.<sup>38</sup> Disinfectant caps containing ethanol instead of IPA have been suggested as an alternative to decrease the risk of toxicity in neonates.<sup>38</sup>

### CONCLUSION

There are numerous issues to be considered for reducing infection risks when accessing vascular catheters. An OLS’s design results in a high rate of intraluminal microbial contamination during clinical use, and neither an IPA pad nor a port-scrub device effectively disinfects an OLS. In contrast, a DNCC’s injection surface can be disinfected with a high level of effectiveness. Although questions remain as to the optimal disinfectant and method of disinfection, and the optimal DNCC design, multiple studies have

See “Vascular Catheters,” Next Page

**Table 3: <sup>a,b</sup>Recommendations for DNCC Disinfection from Selected National and International Organizations**

Organization	Year	Method	Duration	Disinfectant	Drying
American Society of Anesthesiologists <sup>29</sup>	2020	“Clean...before each access”	NM	“Appropriate antiseptic, e.g., alcohol”	NM
SHEA Anesthesia Recommendations <sup>15</sup>	2019	Either a) appropriately use IPA cap or b) “scrub” immediately before each single access or a rapid series of injections (e.g., anesthesia induction)	NM	“Alcohol-based disinfectant”	NM
CDC <sup>30</sup>	2017	“Scrubbing” the access port; “Access the port only with sterile devices”	NM	“CHG, povidone iodine, an iodophor, or 70% alcohol”	NM
APIC <sup>2</sup>	2016	“Vigorously apply mechanical friction” “Follow institutional policy [for] wiping method”	NM	CHG/alcohol, IPA or other approved disinfectant or use IPA cap	“Allow adequate dry time”
APIC CLABSIs Guide <sup>31</sup>	2015	“Scrub”	15 seconds	“Alcohol or CHG/alcohol”	NM
SHEA and other major organizations <sup>32</sup>	2014	“Vigorously apply mechanical friction” If high CLABSI rates despite basic methods, use IPA caps and other measures (e.g., antiseptic catheters and dressings)	≥5 seconds	“Alcoholic CHG, 70% alcohol, or povidone-iodine”	NM
United Kingdom epic <sup>33</sup>	2014	“The hub should be cleaned”	≥15 seconds	“CHG/IPA” “(povidone-iodine/alcohol for CHG-sensitive patients)”	“Allowed to dry”

Abbreviations: APIC, Association for Professionals in Infection Control and Epidemiology; CDC, U.S. Centers for Disease Control and Prevention;

CHG, chlorhexidine gluconate; CLABSI, central-line-associated bloodstream infection; IPA, 70% isopropyl alcohol;

NM, not mentioned in Recommendation; SHEA, Society for Healthcare Epidemiology of America

<sup>a</sup> for additional Guidelines see references Greene,<sup>1</sup> Hallam<sup>34</sup>

<sup>b</sup> items in quotations are the terminology used in each reference; i.e., not all stated “scrub” as the Method used

# Health Care Provider Compliance With Hand Hygiene and Aseptic Technique is Paramount to Reduce Infection Risk

## From “Vascular Catheters,” Preceding Page

found lower rates of intraluminal contamination with disinfected DNCCs compared to OLSs, and some studies have found lower rates of HAIs for disinfected DNCCs compared to OLSs. No current studies have found that OLSs are beneficial compared to disinfected DNCCs. Manufacturers should supply IV tubing sets with DNCCs and DNCC-stopcocks instead of OLSs, and DNCC-stopcocks should also be available as single items. Arterial tubing sets should include a DNCC-stopcock for blood sampling and a device for zeroing the transducer that maintains intraluminal sterility. OLSs should be restricted to use on sterile fields. Health care provider compliance with DNCC disinfection is critical to safe use of DNCCs and should include periodic assessments and re-education on hand hygiene and aseptic technique. Increased use of manufacturer or pharmacy-prepared medications and infusions and use of safe injection practices are also recommended to reduce the risk of vascular access-related HAIs and medication errors. Although a consensus on the optimal approach to DNCC disinfection is lacking and many questions remain, a synthesis of the current literature indicates that immediately before access (or a rapid series of injections) the DNCC should be scrubbed with an alcohol-containing disinfectant for at least 5 seconds (some recommendations are to use  $\geq 15$  seconds), or properly use an IPA cap, followed by drying before injection. IPA caps have potential advantages compared to manual scrubbing; however, additional studies are needed to determine whether IPA caps are more effective for reducing HAIs than the present alternative methods, and whether they are safe for use in neonates.

*Elliott S. Greene, MD, is a professor of anesthesiology in the Department of Anesthesiology at Albany Medical College, Albany, NY.*

*The author has no conflicts of interest.*

## REFERENCES

- Greene ES. Challenges in reducing the risk of infection when accessing vascular catheters. *J Hosp Infect.* 2021;113:130–144.
- Dolan SA, Arias KM, Felizardo G, et al. APIC position paper: Safe injection, infusion, and medication vial practices in health care. *Am J Infect Control.* 2016;44:750–757.
- Holroyd JL, Paulus DA, et al. Universal intravenous access cleaning device fails to sterilize stopcocks. *Anesth Analg.* 2014;118:333–343.
- Rowlands J, Yeager MP, Beach M, et al. Video observation to map hand contact and bacterial transmission in operating rooms. *Am J Infect Control.* 2014;42:698–701.
- Institute for Safe Medication Practices Safe Practice Guidelines for Adult IV Push Medications. <https://www.ismp.org/sites/default/files/attachments/2017-11/ISMP97-Guidelines-071415-3-%20FINAL.pdf> Last accessed October 10, 2021.
- Anesthesia Patient Safety Foundation. Recommendations for improving medication safety consensus from four work groups at the 2018 APSF Stoelting Conference on Medication Safety. Rochester, MN: APSF; 2018. <https://www.apsf.org/medication-safety-recommendations> Last accessed October 10, 2021.
- Centers for Disease Control and Prevention. Safe injection practices to prevent transmission of infections to patients. Atlanta, GA. [https://www.cdc.gov/injectionsafety/ip07\\_standardprecaution.html](https://www.cdc.gov/injectionsafety/ip07_standardprecaution.html) Last accessed October 1, 2021.
- Mermel LA, Bert A, Chapin KC, LeBlanc L. Intraoperative stopcock and manifold colonization of newly inserted peripheral intravenous catheters. *Infect Control Hosp Epidemiol.* 2014;35:1187–1189.
- Loftus RW, Koff MD, Burchman CC, et al. Transmission of pathogenic bacterial organisms in the anesthesia work area. *Anesthesiology.* 2008;109:399–407.
- Loftus RW, Brindeiro BS, Kispert DP, et al. Reduction in intraoperative bacterial contamination of peripheral intravenous tubing through the use of a passive catheter care system. *Anesth Analg.* 2012;115:1315–1323.
- Rupp ME, Yu S, Huerta T, et al. Adequate disinfection of a split-septum needleless intravascular connector with a 5-second alcohol scrub. *Infect Control Hosp Epidemiol.* 2012;33:661–665.
- Slater K, Cooke M, Fullerton F, et al. Peripheral intravenous catheter needleless connector decontamination study - randomized controlled trial. *Am J Infect Control.* 2020;48:1013–1018.
- Casey A, Karpanen T, Nightingale P, Elliott T. An *in vitro* comparison of microbial ingress into 8 different needleless IV access devices. *J Infus Nurs.* 2015;38:18–25.
- Loftus RW, Patel HM, Huysman BC, et al. Prevention of intravenous bacterial injection from health care provider hands: the importance of catheter design and handling. *Anesth Analg.* 2012;115:1109–1119.
- Munoz-Price LS, Bowdle A, Johnston BL, et al. Infection prevention in the operating room anesthesia work area. *Infect Control Hosp Epidemiol.* 2019;40:1–17.
- Voor In't Holt AF, Helder OK, Vos MC, et al. Antiseptic barrier cap effective in reducing central line-associated bloodstream infections: a systematic review and meta-analysis. *Int J Nurs Stud.* 2017;69:34–40.
- Merrill KC, Sumner S, Linford L, et al. Impact of universal disinfectant cap implementation on central line associated bloodstream infections. *Am J Infect Control.* 2014;42:1274–1277.
- Mermel LA. What is the predominant source of intravascular catheter infections? *Clin Infect Dis.* 2011;52:211–212.
- Moureau NL, Flynn J. Disinfection of needleless connector hubs: clinical evidence systematic review. *Nurs Res Pract.* 2015;2015:796762.
- Ryan AJ, Webster CS, Merry AF, Grieve DJ. A national survey of infection control practice by New Zealand anaesthetists. *Anaesth Intensive Care.* 2006;34:68e74
- Balikci E, Yilmaz B, Tahmasebifar A, et al. Surface modification strategies for hemodialysis catheters to prevent catheter-related infections: a review. *J Biomed Mater Res B Appl Biomater.* 2021;109:314–327.
- Arciola CR, Campoccia D, Montanaro L. Implant infections: adhesion, biofilm formation and immune evasion. *Nat Rev Microbiol.* 2018;16:397–409.
- Gominet M, Compain F, Beloin C, Lebeaux D. Central venous catheters and biofilms: where do we stand in 2017? *Acta Pathol Microbiol Immunol Scand.* 2017;125:365–375.
- Greene ES. New SHEA expert guidance for infection prevention in the anesthesia work area needs improvement. *Infect Control Hosp Epidemiol.* 2019;40:607–608.
- Deloney V, Bowdle A, Birnbach DJ, et al. Reply to Greene: New SHEA expert guidance for infection prevention in the anesthesia work area needs improvement. *Infect Control Hosp Epidemiol.* 2021;25:1.
- US Occupational Safety and Health Administration. Bloodborne pathogens and needlestick prevention. Washington, DC. <https://www.osha.gov/SLTC/bloodbornepathogens/index.html>. Last accessed October 1, 2021.
- Rickard CM, Flynn J, Larsen E, et al. Needleless connector decontamination for prevention of central venous access device infection: a pilot randomized controlled trial. *Am J Infect Control.* 2021;49:269–273.
- Flynn JM, Rickard CM, Keogh S, Zhang L. Alcohol caps or alcohol swabs with and without chlorhexidine: an *in vitro* study of 648 episodes of intravenous device needleless connector decontamination. *Infect Control Hosp Epidemiol.* 2017;38:617–619.
- Practice guidelines for central venous access 2020: an updated report by the American Society of Anesthesiologists Task Force on Central Venous Access. *Anesthesiology.* 2020;132:8–43.
- O'Grady NP, Alexander M, Burns LA, et al. Healthcare Infection Control Practices Advisory Committee. Guidelines for the prevention of intravascular catheter-related infections. Atlanta, GA: Centers for Disease Control and Prevention; updated October 2017. Available at: <https://www.cdc.gov/infectioncontrol/pdf/guidelines/bsi-guidelines-H.pdf> Last accessed November 23, 2021.
- Association for Professionals in Infection Control and Epidemiology. Guide to preventing central line-associated bloodstream infections. Washington, DC: APIC; 2015. [http://apic.org/Resource/\\_TinyMceFileManager/2015/APIC\\_CLABSI\\_WEB.pdf](http://apic.org/Resource/_TinyMceFileManager/2015/APIC_CLABSI_WEB.pdf). Last accessed October 1, 2021.
- Marschall J, Mermel LA, Fakhri M, et al. Society for Healthcare Epidemiology of America. Strategies to prevent central line-associated bloodstream infections in acute care hospitals: 2014 update. *Infect Control Hosp Epidemiol.* 2014;35:753–771.
- Loveday HP, Wilson JA, Pratt RJ, et al. UK Department of Health. epic3: National evidence based guidelines for preventing healthcare-associated infections in NHS hospitals in England. *J Hosp Infect.* 2014;86(Suppl. 1):S1–70.
- Hallam C. (2019) Right Hub Disinfection for Compliance. In: Moureau N. (eds) Vessel Health and Preservation: The Right Approach for Vascular Access. pp 235–241 Springer, Cham. [https://doi.org/10.1007/978-3-030-03149-7\\_18](https://doi.org/10.1007/978-3-030-03149-7_18). Online June 11, 2019. Last accessed November 22, 2021.
- Casey AL, Karpanen TJ, Nightingale P, Elliott TS. The risk of microbial contamination associated with six different needle-free connectors. *Br J Nurs.* 2018;27:S18–S26.
- Slater K, Fullerton F, Cooke M, et al. Needleless connector drying time - how long does it take? *Am J Infect Control.* 2018;46:1080–1081.
- Sauron C, Jouvot P, Pinard G, et al. Using isopropyl alcohol impregnated disinfection caps in the neonatal intensive care unit can cause isopropyl alcohol toxicity. *Acta Paediatr.* 2015;104:e489–493.
- Hjalmarsson LB, Hagberg J, Schollin J, Ohlin A. Leakage of isopropanol from port protectors used in neonatal care-Results from an *in vitro* study. *PLoS One.* 2020;15:e0235593.
- Bell T, O'Grady NP. Prevention of central line-associated bloodstream infections. *Infect Dis Clin N Am.* 2017;31:551–559.

## Fostering a Learning Culture that Supports a Trainee's Wellness

by Lynn Reede, DNP, MBA, CRNA, FNAP

Personal and professional wellness are the foundation of vigilant and safe perioperative practice and patient care. The pandemic's impact on health care providers' overall health and well-being are evidenced by increased rates of burnout, depression, substance use, and suicide that threaten the providers' ability to provide safe and optimal patient care.<sup>1</sup> It requires a comprehensive strategy to implement and sustain a positive organizational and learning culture to foster clinician and trainee or learner well-being.

Imagine for a moment that you are a trainee, student, or learner from one of the many perioperative professions entering some phase of care to begin your clinical experience. As a trainee now or when you were a trainee, you are entering a place where your only experience, other than reading about your chosen profession and perhaps shadowing for a few hours, might be a place where you or your family or friends have had a procedure that was filled with many unknowns. Now you are entering a very complex system grounded in science and policy with many professional languages, traditions, and standards of care. As a trainee, you may be concerned about how you will be perceived. You hope to be perfect and realize that in the end perfection and "looking good" is just not possible. You may internalize the following questions: Will your faculty have time or interest to connect what you have learned in the classroom and simulation lab with actual practice? Who will partner with you and how will you be supported for your personal safety and wellness so that you can learn without harming your patient or yourself? Additionally, many first days occur across a health care education program with changing faculty, teams, specialty rotations, and new facilities each with their own learning culture or environment making self-efficacy and confidence even more challenging.

The perioperative period has a culture of its own that is influenced by the organizational culture and subcultures of the professions that have unique languages and customs.<sup>2,3</sup> The trainee, student, or learner is seeking a physical and psychological environment with an educational tone that welcomes them and supports their learning, when in fact they may be faced with some preceptors or clinical faculty who will make the learning process very difficult and uncomfortable.<sup>4</sup> Medical students who experienced negative faculty role modeling during their training were at higher risk of developing burnout.<sup>5</sup> In addition, medical students were at higher risk of depression and burnout if faculty members were perceived to have high demands

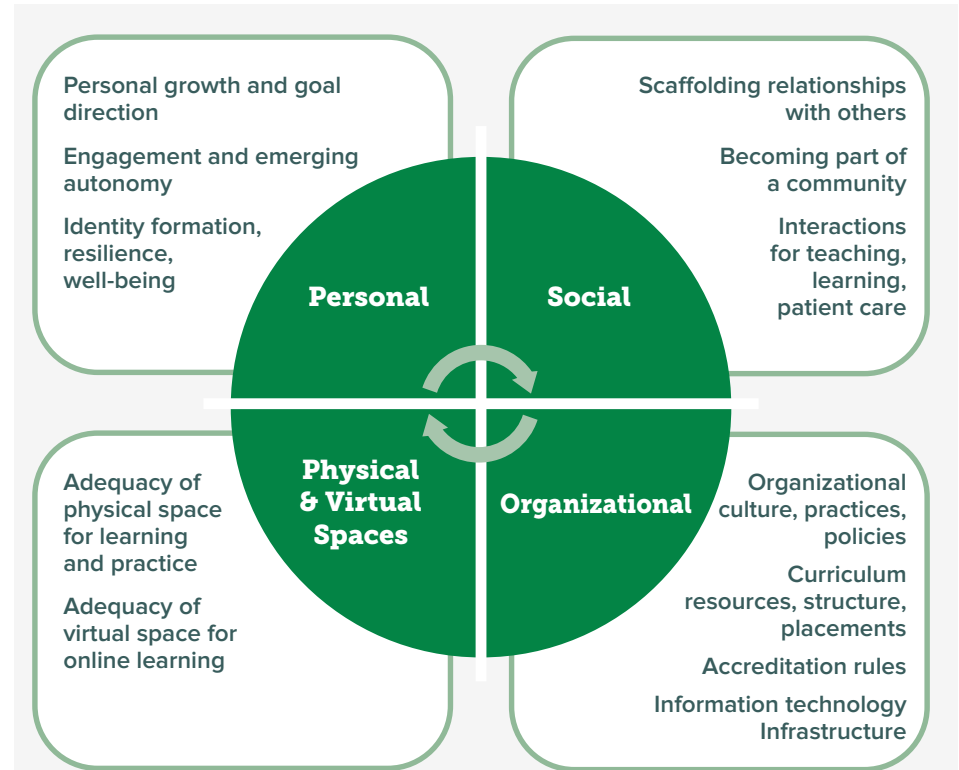

Figure 1: Learning environment interactive components.<sup>7</sup> Used with permission by MedEdPublish.

with little support, did not support student autonomy, and were hostile or harassing. Students who experienced faculty who made education their priority were at lower risk of developing burnout.<sup>5</sup> In a recent study, student registered nurse anesthetists (SRNAs) shared that balancing the demands of the rigorous anesthesia and DNP curriculum and their well-being was not appreciated by some clinical faculty, increasing stress and anxiety. The students suggested that a supportive and genuine relationship with certified registered nurse anesthetist clinical site coordinator(s) improved well-being.<sup>6</sup>

The learning environment or culture has four interactive and overlapping components which are the personal, social, organizational, and physical/ virtual as described in Figure 1.<sup>7</sup> When considering these four overlapping and interactive components of the learning environment, it becomes evident that the trainee's experience and perception of themselves in the learning environment and culture can impact their wellness. The COVID-19 pandemic disrupted the learning environment and interrupted required clinical experiences, as well as how all care is delivered. The pandemic turned the health system on its head, placing clinicians and train-

ees in the position of changed roles with little clarity of what success looked like and no sign of normalcy returning with surge after surge that increased burnout characterized by high emotional exhaustion, depersonalization, and low sense of personal accomplishment.<sup>8</sup> In the 2019 National Academies of Sciences, Engineering and Medicine (NASEM) Taking Action Against Clinician Burnout Consensus Study Report, the Committee found that clinicians who are experiencing burnout, defined as emotional exhaustion, depersonalization, and loss of professional efficacy, are poor teachers and role models who can disrupt the learning environment.<sup>8</sup>

Much has been said about the trainee taking care of themselves. Indeed, regular exercise with proper diet and sleep are foundational to everyone's wellness, but is it enough? When you are engaged in rigorous didactic learning that must be linked to skills, techniques, complex communication, and critical thinking of an autonomous health care provider, you may need a bit more to be well. A trainee's early perception of themselves and

See "Trainee Wellness," Next Page



# Trainee Wellness: Vital For Our Profession's Future

**From “Trainee Wellness,” Preceding Page**

their learning environment are often fixed in their mindset and can be very black and white—be perfect and look good to others or you are a failure.<sup>9</sup> The fixed mindset does not support learning or resilience necessary for successful and safe health care practice. Over and over again, throughout an education or training program, the faculty and health care team have opportunities to foster the learning culture that is safe for the learner to move from the fixed to growth mindset.<sup>9-11</sup> The growth mindset provides the trainee with a frame of reference; permission if you will, to learn from challenges, feedback, and mistakes.<sup>9-11</sup> In an effective learning culture, faculty and students are able to plan for a successful learning day by creating clear, measurable goals to create a timely feedback loop during the clinical day to assess understanding and at the end of the time together. This feedback can identify successes, questions to be answered from the literature and text, and what learning goals are next.<sup>5</sup> The student who is resilient and possesses grit is well and confident to seek difficult, challenging learning experiences when the faculty and culture are aligned in a positive learning culture. These students will also know when to ask for help for personal and patient safety.

Fostering a learning culture for trainee or learner wellness uses strategies that promote well-being, empathy, and the learning experience linking the learner, faculty, and culture to create community, eliminate mistreatment, address misperceptions with conversation, continuously improve the learning experience, foster a growth mindset in learners and faculty, and finally mitigate stigma of seeking help (Table 1).<sup>5,7,11</sup> Our trainees, no matter their profession, are our future. Investing across our organizations to foster an interprofessional learning culture and environment will pay dividends in

attracting and retaining engaged professionals, and will also improve the wellness of our trainees to be vigilant, engaged health care providers focused on patient and provider safety.<sup>12</sup> The health care organization has the opportunity to include learners and staff in anonymous surveys to assess organizational culture and learning culture effectiveness, as well as impact on wellness, burnout, and learning.<sup>7,12</sup> Beyond the clinical site, social activities arranged outside of didactic and clinical time allow students to connect with each other to improve the education experience.<sup>6</sup> Wellness days during the education program promote work-life balance.<sup>6</sup> Clinical faculty and perioperative team members have an opportunity to connect with students to foster them into their professional role through inclusion in team conversations and communications, education and quality improvement activities, birthday and other celebrations, and social gatherings outside of the clinical site. Being part of a community which genuinely connects with the student as a person will provide the students with a safe place to learn and grow to be well.

Educating and mentoring our trainees, students, and learners in a healthy and well learning environment is a complex and critical issue.<sup>8</sup> It demands our attention and commitment to monitor our students, culture, metrics, and ourselves for wellness linked with safety and, most of all, to ask our trainees, are you OK? Then we should continue to support the future of health care, our learners, for continued wellness or guide the learner to resources to gain wellness for their own and patient’s safety.<sup>13</sup>

*Lynn Reede, DNP, MBA, CRNA, FNAP, is an associate clinical professor in the Nurse Anesthesia Program at Northeastern University, Boston, MA. She is a member of the APSF Executive Committee and Board of Directors.*

*The author has no conflicts of interest.*

**REFERENCES**

1. Health Policy Institute of Ohio. A call to action. Improving clinician well-being and patient care and safety. 2020.
2. Allen MP, Johnson RE, McClave EZ, Alvarado-Little W. Language, interpretation, and translation: a clarification and reference checklist in service of health literacy and cultural respect. National Academy of Medicine. February 18, 2020 <https://nam.edu/language-interpretation-and-translation-a-clarification-and-reference-checklist-in-service-of-health-literacy-and-cultural-respect/>. Accessed November 20, 2021.
3. Raksamani, K., Stalmeijer, R.E. How postgraduate trainees from different health professions experience the learning climate within an operating theater: a mixed-methods study. *BMC Med Educ.* 2019;19:1–11. [doi.org/10.1186/s12909-019-1648-1](https://doi.org/10.1186/s12909-019-1648-1)
4. McKimm J, Nishigori H. The implications of culture in the education and practice of healthcare professionals. *The Asia-Pacific Scholar.* 2019;4:1–2. [doi.org/10.29060/TAPS.2019-4-3/EV4N3](https://doi.org/10.29060/TAPS.2019-4-3/EV4N3)
5. Dyrbye LN, Satele D, West CP. Association of characteristics of the learning environment and US medical student burnout, empathy, and career regret. *JAMA Netw Open.* 2021;4:e2119110. [dx.doi.org/10.1001%2Fjamanetworkopen.2021.19110](https://doi.org/10.1001%2Fjamanetworkopen.2021.19110)
6. Mesisca J, Mainwaring J. Stress, anxiety, and well-being in nurse anesthesia doctoral students. *AANA Journal.* 2021;89:396–402.
7. Gruppen L, Irby D, Durning S, Maggio L. Interventions designed to improve the learning environment in the health professions: a scoping review. *MedEdPublish.* 2018;7:1–32. [doi.org/10.15694/mep.2018.00002111](https://doi.org/10.15694/mep.2018.00002111)
8. National Academies of Sciences, Engineering, and Medicine. Taking action against clinician burnout: a systems approach to professional well-being. *The National Academies Press.* 2019. [doi.org/10.17226/25521](https://doi.org/10.17226/25521)
9. Bartlett AD, Um IS, Luca EJ, et al. Measuring and assessing the competencies of preceptors in health professions: a systematic scoping review. *BMC Medical Education.* 2020; 20:165. [doi.org/10.1186/s12909-020-02082-9](https://doi.org/10.1186/s12909-020-02082-9)
10. Dweck C. Mindset: The new psychology of Success. Ballantine Books. 2007. <https://www.mindsetworks.com>
11. Theard MA, Marr MC, Harrison R. The growth mindset for changing medical education culture. *EClinicalMedicine.* 2021; 37:100972 [doi.org/10.1016/j.eclinm.2021.100972](https://doi.org/10.1016/j.eclinm.2021.100972)
12. Dyrbye LN, Lipscomb W, Thibault G. Redesigning the learning environment to promote learner well-being and professional development. *Acad Med.* 2020;95:674–678. [doi.org/10.1097/acm.0000000000003094](https://doi.org/10.1097/acm.0000000000003094)
13. Huang J, Brenner A. Our own safety. *APSF Newsletter.* 2019;33:82–83. <https://www.apsf.org/article/our-own-safety/>

**Table 1: Learning Culture<sup>8</sup>**

Learning Culture Connects Everyone for Learner Wellness & Safety	
<b>Learner</b>	<ul style="list-style-type: none"> <li>• Create community for &amp; between students</li> <li>• Eliminate mistreatment</li> </ul>
<b>Faculty</b>	<ul style="list-style-type: none"> <li>• Address misperceptions with conversation</li> <li>• Continuously improve the learning experience</li> </ul>
<b>Learning Culture</b>	<ul style="list-style-type: none"> <li>• Foster growth mindset in learners and faculty</li> <li>• Mitigate stigma of seeking help</li> </ul>

# Anesthetic Safety Considerations for Off-site Cardiology Procedures

by Todd Novak, MD, and Chelsea Zur, MD

## INTRODUCTION

Rapid advancements in the fields of electrophysiology (EP) and interventional cardiology have increased the demand for anesthesia services.<sup>1,2</sup> These procedures have grown in complexity and often involve the care of acutely sick patients with multiple comorbidities including advanced cardiac and pulmonary disease. Providing anesthesia for patients undergoing these procedures at an off-site location can be challenging where the environment and equipment may be unfamiliar, space is limited, and with physical barriers between the anesthesia professional and the patient. Analysis of the ASA closed claims database indicates a significant number of injuries occur in the cardiology suite (EP and catheterization lab), second only to the gastroenterology lab.<sup>3</sup> Understanding and preparing for the inherent challenges of providing anesthesia in these areas may enhance patient safety.

## PREOPERATIVE EVALUATION

Preprocedural evaluation should include a thorough history and physical; review of allergies, specifically an allergy to iodinated contrast; and medication reconciliation. Special attention should be paid to anticoagulants and heart failure regimens. With the exception of ablation procedures, beta-blockers and antiplatelet medications are typically continued in the periprocedural setting.<sup>2,4</sup> If a preoperative anesthesia clinic is available, additional evaluation of certain high-risk patients or procedures may be warranted (Table 1).

As these patients are commonly followed by a cardiologist, there may be an extensive workup already completed. A 12-lead electrocardiogram, echocardiogram, and cardiac monitoring report may be available for review. If the patient has a cardiovascular implantable electronic device, the anesthesia professional should review the manufacturer, current settings, indication for placement, and whether the patient is pacemaker-dependent. The most recent Practice Advisory from the American Society of Anesthesiologists in 2020 did not reach a consensus on the time frame at which a device interrogation should be completed prior to an elective procedure, though the report stated that a majority of ASA members and consultants recommend interrogation 3–6 months prior to the planned procedure.<sup>5</sup>

Preoperative laboratory testing varies depending on the type of intervention and risk

**Table 1: High-Risk Patient Factors That May Warrant Preprocedural Anesthesia Evaluation Prior to Their Off-Site Cardiology Procedure**

Morbid obesity, obstructive sleep apnea, difficult airway
Congestive heart failure, inability to lie flat
Severe pulmonary disease
Substance abuse disorders, psychiatric disorders
Complex arrhythmia ablations
Procedures requiring general anesthesia

for bleeding. Labs may include a complete blood count, type and screen, coagulation studies, and basic metabolic panel, particularly if contrast is to be used.

## ELECTROPHYSIOLOGY LAB

Regardless of the ablation technique employed, complications may arise and need to be addressed immediately as decompensation can be rapid. The most common complication is related to vascular access injuries followed by cardiac perforation/tamponade.<sup>6</sup> Perforation needs to be emergently treated by immediate reversal of anticoagulation and pericardiocentesis. The anesthesia professional should be prepared to rapidly administer blood products and start vasopressor infusions when necessary. If hemodynamic collapse ensues and transport to the operating room for a surgical intervention is required, preprocedural planning between the anesthesia and electrophysiology teams on the logistics of transporting an unstable patient will save valuable time. Other potential periprocedural complications include cerebrovascular accident, heart block, pulmonary edema, phrenic nerve palsy, esophageal perforation, and, rarely, pulmonary hemorrhage.<sup>6-8</sup>

Large-bore intravenous lines, arterial catheters, and/or central catheters should be placed prior to the start of the procedure, as once the patient is draped, it can be impossible to access the patient if an emergency arises. Arterial access is preferred in patients where hemodynamic instability is anticipated or the procedure will be long in duration. Often times, arterial pressure monitoring is obtained by the electrophysiologist as part of the procedure; however, it should be noted the waveform may dampen and become inaccurate if the lumen of the arte-

rial sheath is occluded by a device. Many anesthesia professionals may consider obtaining their own invasive blood pressure monitoring in order to avoid this pitfall and as a way to follow arterial blood gases throughout the procedure. A preprocedural discussion with the electrophysiologist concerning these issues is essential in avoiding blood pressure monitoring difficulty.

Further complicating the anesthesia care are large pieces of equipment for cardiac mapping and fluoroscopic imaging that serve as a physical barrier between the anesthesia team and the patient's airway. Additionally, the operating table and fluoroscopic C-arm are controlled by the electrophysiologist, which may result in accidental dislodgment of the breathing circuit, intravenous lines, and monitors. These circumstances should be anticipated and extensions added to lines.

## CATHETER-BASED ABLATIONS

Catheter ablations are a mainstay treatment option for supraventricular tachycardia (SVT), atrial flutter (AFL), atrial fibrillation (AF), and ventricular tachycardia (VT) with the goal of creating a transmural lesion that permanently eradicates arrhythmogenic cardiac tissue without causing collateral injury to adjacent structures. Shorter duration procedures such as SVT and AFL ablations can be performed without an anesthesia professional using moderate sedation by a qualified nurse under the supervision of the electrophysiologist. However, more complex procedures that require significant time for mapping and ablating may best be performed with an anesthesia professional under monitored anesthesia care or general anesthesia.

See "Cardiology Procedures," Next Page

# Anesthetic Agents May Have Electrophysiologic Effects

From “Cardiology Procedures,” Preceding Page

It should also be noted many commonly administered anesthetic drugs may suppress arrhythmia inducibility; therefore, preprocedural discussion with the electrophysiology team is important in determining the appropriate anesthetic for the patient (Table 2).<sup>9</sup>

### Radiofrequency (RF) ablation

Radiofrequency (RF) ablation of the endocardium is the most widely used technique for a variety of arrhythmias where electromagnetic energy is converted to thermal energy resulting in an irreversible thermal injury to myocardial tissue. Typically, active cooling through saline administration at the tip of the catheter is performed in order to prevent collateral injury from excess temperatures at the electrode-tissue interface.<sup>19</sup> A useful intervention when an RF procedure involves the left atrium (i.e., AF ablation) is to place an esophageal temperature probe which allows continuous temperature monitoring minimizing this risk to adjacent structures such as the esophagus. Maintaining an esophageal temperature ≤38.5°C may be associated with a decrease in esophageal injuries such as ulceration and left atrial-esophageal fistula formation.<sup>20</sup> Also, active cooling may result in several liters of saline being administered by the electrophysiologist over the course of the procedure and must be taken into account when assessing overall fluid balance. This is especially true for patients with poor ventricular function.

### Cryoballoon ablation

Cryoballoon ablation is a newer technology, mainly used in the treatment of AF, that freezes the endocardium resulting in impaired propagation of aberrant electrical signals. A balloon-tipped catheter is inserted into a pulmonary vein that, when inflated, circumferentially freezes the surrounding tissue. One technical consideration for the anesthesia professional is the avoidance of muscle relaxants because phrenic nerve stimulation is often employed. Phrenic nerve palsy is one of the most common complications after cryoballoon ablation.<sup>21</sup>

### Epicardial Ablation

An epicardial approach to ablation may be employed for certain ventricular arrhythmias and as part of a hybrid surgical-catheter technique for AF. The hybrid approach is a relatively new technique where both the epicardium and endocardium are treated, which may provide some added benefit in the treatment of AF by combining both surgical (epicardial) and catheter (endocardial) approaches.<sup>22</sup> These epicardial procedures are exclusively performed under general anesthesia. If hypotension is

**Table 2: Anesthetic Agents and Their Electrophysiologic Effects**

Anesthetic Agent	Electrophysiologic Effects	Special Considerations
Sevoflurane	↑ QTc Enhance ectopic atrial rhythms No effect on SA and AV nodes No effect on accessory pathway	Safe to use
Desflurane	↑ QTc Inhibitory effects on AV node Tachycardia	Sympathomimetic ?Arrhythmogenic
Propofol	Inhibitory or no effects on SA node Inhibitory or no effects on AV node No effect on accessory pathway Bradycardia	May not be suitable for ectopic atrial tachycardia ablation; <sup>10</sup> suppresses electrical storm <sup>11,12</sup>
Midazolam	? Vagolysis ? Tachycardia	
Rocuronium	Minimum effects on automaticity	Avoid during phrenic nerve pacing
Vecuronium	Minimum effects on automaticity	Avoid during phrenic nerve pacing
Succinylcholine	Inhibitory effects on AV node Bradycardia or tachycardia	
Remifentanyl	Inhibitory effects on SA, AV node Bradycardia	May not be optimal for AVRT and AVNRT ablation in pediatric patients <sup>13</sup>
Fentanyl	↑ Vagal tone	No issues in EP procedures when combined with midazolam
Sufentanil	May ↑ QTc No effect on accessory pathway	
Dexmedetomidine	Enhance vagal activity ↓ Norepinephrine release ↓ Sympathetic tone Bradycardia	Antiarrhythmic in pediatric patients <sup>14-16</sup> ; may not be suitable in EP lab <sup>17,18</sup>
Ketamine	Minimal effects on SA and AV nodes ↑ Atrial conduction time	↑ Heart rate ± BP

Abbreviations: AV, atrioventricular; AVNRT, atrioventricular nodal reentrant tachycardia; AVRT, atrioventricular reentrant tachycardia; BP, blood pressure; EP, electrophysiology; SA, sinoatrial

Adapted from the *Journal of Cardiothoracic and Vascular Anesthesia*, Vol 32, Issue 4. Satoru Fujii, Jian Ray Zhou, Achal Dhir, *Anesthesia for Cardiac Ablation*, Pages 1892–1910, Copyright (2018), with permission from Elsevier.

encountered during an epicardial approach, unique complications that should be suspected include injury to a coronary artery and intra-abdominal bleeding.<sup>7</sup>

### CATHETERIZATION LABORATORY Transcatheter Aortic Valve Replacement

Over the last several years, the indications and anesthetic considerations for Transcatheter Aortic Valve Replacement (TAVR) have evolved. Once only indicated for patients with severe, symptomatic aortic stenosis (AS) for whom surgical aortic valve replacement was deemed too high risk, approval was recently expanded for

use in low-risk, symptomatic patients with AS.<sup>23,24</sup> Furthermore, TAVR is being evaluated for asymptomatic patients with severe AS.

There are currently two TAVR systems used in the United States; the Edwards Sapien valves and the Medtronic CoreValve family of devices. The Sapien valve is a low profile, balloon expandable valve that cannot be repositioned following deployment, whereas the CoreValve family of valves is self-expanding, higher profile, and can be partially recaptured and repositioned for optimal placement.

See “Cardiology Procedures,” Next Page



## Anesthesia Care During Percutaneous Aortic or Mitral Valve Replacement is Critical

From “Cardiology Procedures,” Preceding Page

Use of the Sapien valve or performance of balloon aortic valvuloplasty prior to valve deployment requires rapid ventricular pacing (160–220 beats/minute) via a temporary transvenous pacer. This minimizes blood flow in the left ventricular outflow tract thereby reducing the risk of valve migration during deployment.<sup>25</sup> Rapid pacing and subsequent hypotension may not be well tolerated by patients with aortic stenosis, but this situation is usually transient; use of vasopressors such as phenylephrine or norepinephrine should be considered to treat hypotension only if it is persistent as rebound hypertension may develop after pacing ceases.

While overall mortality for TAVR remains low at 1–4%, complications can lead to significant morbidity. The majority of complications are identified intraoperatively and include vascular injury (4.2%), aortic dissection (0.2%), ventricular perforation leading to tamponade (1%), valve malposition and malfunction (0.3%), annular rupture (0.4%), stroke, myocardial infarction, and high degree atrioventricular nodal block requiring permanent pacemaker (8.8%).<sup>26</sup>

The most common approach for device placement is transfemoral (95%). Other approaches include subclavian/axillary, transaortic, transapical, transcaval, and transcarotid. The transfemoral approach has the benefit of minimal discomfort for the patient and minimal sedation requirements. As technology becomes more sophisticated, and interventionalists become more skilled, utilizing mild-moderate sedation for TAVR has grown in popularity. Recent data shows that benefits include less vasopressor use, a modest decrease in in-hospital mortality, shorter hospital length of stay, and more frequent discharge to home.<sup>27</sup> When utilizing sedation with local anesthesia, device placement is confirmed with fluoroscopy and transthoracic echocardiography (TTE).

If transesophageal echocardiography (TEE) is preferred over TTE or when a percutaneous transfemoral approach is not feasible, often due to inadequate iliofemoral vasculature, or a surgical cutdown for vascular repair is required, general anesthesia with an endotracheal tube is utilized. Benefits of general anesthesia include a quiet surgical field, complete control of the airway and early recognition of surgical complications with TEE.

Regardless of anesthesia type, invasive blood pressure monitoring is recommended. This can be accomplished via a radial arterial line or by transducing the arterial sheath used by the inter-



ventionalist for aortography. Large bore, peripheral IV access and immediate access to cross-matched blood is also recommended.

### Transcatheter Mitral Valve Repair or Replacement

Transcatheter mitral valve repair (TMVr) may be considered for patients with symptomatic, moderate-severe, or severe mitral regurgitation for whom surgical valve repair is considered too high risk. The MitraClip device (Abbott Vascular-Structural Heart, Menlo Park, CA) is currently the only device with FDA approval and is performed in a cardiac catheterization lab or hybrid operating room. The MitraClip device is a leaflet repair device and is modeled after the surgical Alfieri stitch which creates an edge-to-edge repair and double orifice mitral valve, thereby reducing the degree of mitral regurgitation.<sup>28</sup>

When performing transcatheter leaflet repair, transfemoral venous cannulation is obtained by the proceduralist. Using real-time fluoroscopic and TEE guidance, the device is directed across the intraatrial septum, through the left atrium and across the mitral valve into the left ventricle. Both two-dimensional and three-dimensional TEE imaging are imperative to accurately position the device. Immediately following MitraClip release, the degree of mitral regurgitation and iatrogenic stenosis are assessed with TEE. If placement is suboptimal, the clip can be retrieved, repositioned, or removed. More than one clip can also be used to reduce the amount of regurgitation, if necessary.<sup>29</sup>

General anesthesia with an endotracheal tube is recommended, given the importance of TEE for device placement. Radial arterial access is typically obtained by the anesthesia professional for close hemodynamic monitoring and blood draws. Frequent lab draws may be required to achieve the desired level of anticoagulation. If radial artery access is challenging, other arterial access sites may be utilized. Central venous line placement is not typically necessary, though large bore IV access is rec-

ommended due to the risk of emergent conversion to open surgical repair. Cross-matched blood should be available in the procedure room.<sup>29</sup>

Complications of TMVr include partial clip detachment or embolization, tamponade, bleeding at access sites, and iatrogenic mitral stenosis. It is important to note that TMVr may result in an iatrogenic atrial septal defect at the site of septal puncture. If a shunt is noted, all intravenous lines should be closely evaluated for air to prevent stroke.

Alternatively, and less commonly performed, transcatheter mitral valve replacement (TMVR) is FDA approved for high-risk patients that have a failing mitral valve previously replaced or repaired with a bioprosthetic valve or annuloplasty ring, respectively. The Edwards Sapien 3 or Sapien 3 Ultra, which are designed for TAVR, are used in these patients for valve-in-valve or valve-in-ring replacement. Some institutions are also using TAVR valves in an off-label manner to treat end-stage, refractory native mitral valve disease. TMVR technology is still evolving and its use has been limited due to poor outcomes. Similar to TMVr, general anesthesia is typically used for TMVR due to the necessary use of TEE.

### ADDITIONAL OFFSITE CARDIAC PROCEDURES

#### Diagnostic Transesophageal Echocardiography

TEE is utilized to better visualize cardiac structures that are not well visualized by TTE. While routine use of TEE is not appropriate, as TTE carries little to no risks and is often times diagnostically adequate, there are several clinical situations where TEE is preferred. Clinical indications for TEE may include valvular pathology and surgical planning, urgent assessment of acute aortic pathology (i.e., aortic dissection), diagnosis of infectious endocarditis, and prior to nonemergent direct-current cardioversion (DCCV) or ablation to assess for intracardiac thrombus.

See “Cardiology Procedures,” Next Page

# Anesthesia Professionals Should Be Aware of the Off-site Cardiology Peri-Procedural Challenges

## From “Cardiology Procedures,” Preceding Page

Diagnostic TEE is typically performed with moderate sedation. Apnea should be avoided. Careful topicalization of the pharynx with lidocaine can be used to decrease the amount of sedation required. Topicalization with benzocaine has fallen out of favor due to the risk of methemoglobinemia. Intravenous glycopyrrolate can also be used to minimize oral secretions.<sup>30</sup> Stimulation associated with TEE probe insertion can be mitigated with a propofol bolus of 0.25–0.5 mg/kg. Following insertion, the degree of stimulation quickly decreases, and moderate sedation can be achieved with a low dose propofol infusion or incremental propofol boluses. Propofol has the benefit of rapid onset and metabolism, and minimal residual effects following the procedure.<sup>28</sup> Alternatively, a dexmedetomidine bolus of 0.5–1 mcg/kg over ten minutes and/or an infusion of 0.2–1 mcg/kg/hour can be used in conjunction with adequate airway topicalization.

In certain high-risk patient populations, such as those with a difficult airway, high aspiration risk, impaired neurologic status or those with airborne precautions, such as COVID-19, general anesthesia with an endotracheal tube may be warranted. As TEE is an aerosolizing procedure, its elective use should be avoided in patients with COVID-19 unless the findings will change clinical management.

Although TEE is a generally safe procedure, complications such as laryngospasm, aspiration, pharyngeal injury, perforated viscus, and hemorrhage do occur. Initial treatment for such adverse events is typically endotracheal intubation and resuscitation.

## Direct-Current Cardioversion (DCCV)

DCCV is usually a short procedure requiring a rapid onset and offset of anesthesia. Following application of standard ASA monitors and capnography, a 0.25–0.5 mg/kg propofol bolus is administered such that the patient is not responsive to tactile or verbal stimulation. Apnea should be avoided. Once deep sedation is confirmed, the electrical shock can be delivered. Patients undergoing DCCV may have low cardiac output, slow circulation time, and delayed onset of induction medications which can lead to oversedation. Medications to treat hypotension and/or bradycardia, such as phenylephrine; ephedrine; and glycopyrrolate or atropine, should be readily available.<sup>28,31</sup> Pre-procedure external defibrillation pads should be placed in the event of post-DCCV asystole and extrinsic pacing is required. If a patient has

an implantable electronic cardiac device, such as a pacemaker or defibrillator, the device should be interrogated immediately following external cardioversion or defibrillation.<sup>8</sup>

## CONCLUSIONS

As cardiac interventions become more sophisticated and less invasive, anesthesia professionals are tasked with providing safe medical care in a wide variety of locations, often far removed from the operating room. Additionally, the patients undergoing such procedures have complex medical histories and are more acutely ill. As an integral component of the care team, it is imperative that the anesthesia professional is familiar with the challenges of off-site procedures, understands the procedure itself, and can anticipate pitfalls so as to provide safe patient care.

*Todd Novak, MD, is an attending anesthesiologist at NorthShore University HealthSystem and clinical assistant professor at the University of Chicago Pritzker School of Medicine.*

*Chelsea Zur, MD, is an attending anesthesiologist at NorthShore University HealthSystem and Clinical Instructor at the University of Chicago Pritzker School of Medicine.*

*The authors have no conflicts of interest.*

## REFERENCES

- Gaitan BD, Trentman TL, Fassett SL, et al. Sedation and analgesia in the cardiac electrophysiology laboratory: a national survey of electrophysiologists investigating the who, how, and why? *J Cardiothorac Vasc Anesth.* 2011;25:647–659.
- Anderson R, Harukuni I, Sera V. Anesthetic considerations for electrophysiologic procedures. *Anesthesiol Clin.* 2013;31:479–489.
- Metzner J, Posner KL, Domino KB. The risk and safety of anesthesia at remote locations: the US closed claims analysis. *Curr Opin Anaesthesiol.* 2009;22:502–508.
- Shook D, Evangelista K. Anesthetic considerations for electrophysiology, interventional cardiology, and transesophageal echocardiography procedures. In: Post TW, ed. UpToDate. UpToDate; 2021. Accessed September 9, 2021.
- Practice Advisory for the Perioperative Management of Patients with Cardiac Implantable Electronic Devices: Pacemakers and Implantable Cardioverter–Defibrillators 2020: An Updated Report by the American Society of Anesthesiologists Task Force on Perioperative Management of Patients with Cardiac Implantable Electronic Devices. *Anesthesiology.* 2020;132:225–252.
- Gupta A, Perera T, Ganesan A, et al. Complications of catheter ablation of atrial fibrillation: a systematic review. *Circ Arrhythm Electrophysiol.* 2013;6:1082–1088.
- Kumareswaran R, Marchlinski FE. Practical guide to ablation for epicardial ventricular tachycardia: when to get access, how to deal with anticoagulation and how to prevent complications. *Arrhythm Electrophysiol. Rev.* 2018;7:159–164.
- Haines DE, Beheiny S, Akar JG, et al. Heart Rhythm Society expert consensus statement on electrophysiology laboratory standards: process, protocols, equipment, personnel, and safety. *Heart Rhythm.* 2014 Aug;11:e9–51.
- Fujii S, Zhou JR, Dhir A. Anesthesia for cardiac ablation. *J Cardiothorac Vasc Anesth.* 2018;32:1892–1910.
- Lai LP, Lin JL, Wu MH, et al. Usefulness of intravenous propofol anesthesia for radiofrequency catheter ablation in patients with tachyarrhythmias: infeasibility for pediatric patients with ectopic atrial tachycardia. *Pacing Clin Electrophysiol.* 1999;22:1358–1364.
- Burjorjee JE, Milne B. Propofol for electrical storm: a case report of cardioversion and suppression of ventricular tachycardia by propofol. *Can J Anaesth.* 2002;49:973–977.
- Mulpuru SK, Patel DV, Wilbur SL, et al. Electrical storm and termination with propofol therapy: a case report. *Int J Cardiol.* 2008;128:e6–8.
- Niksich A, Liberman L, Clapcich A, et al. Effects of remifentanyl anesthesia on cardiac electrophysiological properties in children undergoing catheter ablation of supraventricular tachycardia. *Pediatr Cardiol.* 2010;31:1079–1082.
- Hammer GB, Drover DR, Cao H, et al. The effects of dexmedetomidine on cardiac electrophysiology in children. *Anesth Analg.* 2008;106:79–83.
- Chrysostomou C, Sanchez-de-Toledo J, Wearden P, et al. Perioperative use of dexmedetomidine is associated with decreased incidence of ventricular and supraventricular tachyarrhythmias after congenital cardiac surgery. *Ann Thorac Surg.* 2011;92:964–972.
- Herr DL, Sum-Ping STJ, England M. ICU sedation after coronary artery bypass graft surgery: Dexmedetomidine-based versus propofol-based sedation regimens. *J Cardiothorac Vasc Anesth.* 2003;17:576–584.
- Mittnacht AJC, Dukkkipati S, Mahajan A. Ventricular tachycardia ablation: a comprehensive review for anesthesiologists. *Anesth Analg.* 2015;120:737–748.
- Hayman M, Forrest P, Kam P. Anesthesia for interventional cardiology. *J Cardiothorac Vasc Anesth.* 2012;26:134–147.
- Houmsse M and Daoud EG (2012) Biophysics and clinical utility of irrigated-tip radiofrequency catheter ablation. *Expert Review of Medical Devices.* 9:1,59–70.
- Singh SM, d’Avila A, Doshi SK, et al. Esophageal injury and temperature monitoring during atrial fibrillation ablation. *Circ Arrhythm Electrophysiol.* 2008;1:162–168.
- Tokuda, M., Yamashita, S., Sato, H. et al. Long-term course of phrenic nerve injury after cryoballoon ablation of atrial fibrillation. *Sci Rep* 11, 6226 (2021).
- Driver K, Mangrum JM. Hybrid approaches in atrial fibrillation ablation: why, where and who? *J Thorac Dis.* 2015;7:159–164.
- Mack MJ, Leon MB, Thourani VH, et al. Transcatheter aortic valve replacement with a balloon-expandable valve in low-risk patients. *N Engl J Med.* 2019;380:1695–1705.
- Coylewright M, Forrest J, McCabe J, Nazif T. TAVR in low-risk patients: FDA approval, the new NCD and shared decision-making. *JACC.* 2020;75:1208–1211.
- Novak T, Parulkar S. The anesthesia professional’s role in patient safety during TAVR (transcatheter aortic valve replacement). *APSF Newsletter.* 2017;31:73–75.
- Dalby M, Panoulas V. Transcatheter aortic valve replacement: complications. In: Post TW, ed. UpToDate, UpToDate, 2021. Accessed October 1, 2021.
- Butala NM, Chung M, Secemsky EA, et al. Conscious sedation versus general anesthesia for transcatheter aortic valve replacement: variation in practice and outcomes. *J Am Coll Cardiol Intv.* 2020;13:1277–1287.
- Faillace R, Kaddaha R, Bikkina M, et al. The role of the out-of-operating room anesthesiologist in the care of the cardiac patient. *Anesthesiology Clin.* 2009;27:29–46.
- Gregory SH, Sodhi N, Zoller JK, et al. Anesthetic considerations for the transcatheter management of mitral valve disease. *J Cardiothorac Vasc Anesth.* 2019;33:796–807.
- Hahn R, Abraham T, Adams M, et al. Guidelines for performing a comprehensive transesophageal echocardiographic examination: recommendations from the American Society of Echocardiography and the Society of Cardiovascular Anesthesiologists. *J Am Soc Echocardiography.* 2013;26:921–964.
- Lu F, Lin J, Benditt D. Conscious sedation and anesthesia in the cardiac electrophysiology laboratory. *J Cardiovasc Electrophysiol.* 2013;24:237–245.

# A Summary from the 2021 APSF Stoelting Conference: Clinician Safety: To Care is Human

by Patty Reilly, CRNA; Matthew B. Weinger, MD; and Brian Thomas, JD

## SUMMARY STATEMENTS ON CLINICIAN BURNOUT AND WELL-BEING:

1. A failure to address the crisis of clinician burnout and degraded well-being will be costly to clinicians, patients, and health care organizations.
  - a. Clinician burnout is a significant patient safety issue (unhappy, unhealthy clinicians lead to unhappy, unsafe patients)
  - b. Clinician burnout is a societal workforce issue because replacing one departing perioperative professional can cost 2–3 times that individual's annual salary and facilitate increased turnover of other team members for up to a year.
2. Burnout is a systemic issue and must be addressed at societal and organizational levels. However, individual perioperative professionals can and must be involved to address this complex problem.
3. Any comprehensive/successful solution will require the following elements:
  - a. Leadership commitment to clinician well-being as an institutional core value.
  - b. Real change to an organization's culture. Prioritization of clinician well-being (including psychological safety) and a focus on increasing meaning and purpose in work (e.g., a reduction of low-value tasks).
  - c. Reliable measurement(s) of key metrics of individual and organizational well-being.
  - d. Transparency and feedback
  - e. Multidisciplinary efforts (including surgeons, proceduralists, and nurses) to build a "wellness community"
  - f. Identify and address the most important issues at the local level (Each health care institution will be different).
  - g. Incorporating diversity, equity, and inclusion in all decision making
4. Trainees are a particularly vulnerable population for degraded well-being and must be proactively addressed using similar approaches as described in item 3 above.
5. The allocation of tangible resources to clinician well-being (e.g., leadership roles, physical space) is an important signal to the organization that leadership is serious about this.

## 2021 STOELTING CONFERENCE RECOMMENDATIONS:

1. APSF should consider collaborating with professional societies (e.g., ASA, AANA, AAAA, ACS, and AORN, etc.†) to produce a joint statement on clinician well-being and the effects on patient safety and quality in the perioperative period.
2. APSF should create and lead, in collaboration with other professional societies, the development of a toolbox to support the perioperative care team as they continue to proactively address well-being.
3. APSF should partner with other organizations to support and fund research on the "basic science" of clinician burnout/degraded well-being; expanding the evidence base for effective interventions; and developing best-practices for implementation of best-of-class interventions.
4. Diversity, equity, and inclusion (DEI) are important elements of clinician and organizational well-being. APSF should develop a statement highlighting the effects of DEI on clinician well-being.
5. APSF should create a financial business case for perioperative clinician well-being.
6. APSF should partner with perioperative colleagues to enhance education on clinician well-being that should include podcasts and webinars.
7. Consider publication of data on clinician safety shared at the conference in a future *APSF Newsletter* publication.

\*ASA—American Society of Anesthesiologists; AANA—American Association of Nurse Anesthesiology; AAAA—American Academy of Anesthesiologist Assistants; ACS—American College of Surgeons; AORN—Association of Perioperative Registered Nurses

*Patty Mullen Reilly is a CRNA at Chester County Hospital, Penn Medicine in West Chester, PA. She is also a part of the Clinical Research and Medical Science team within the Patient Monitoring and Respiratory Interventions businesses for Medtronic which is located in Boulder, CO.*

*Matthew B. Weinger, MD, MS, is the Norman Ty Smith Chair in Patient Safety and Medical Simulation and professor of anesthesiology, biomedical informatics and medical education at the Vanderbilt University School of Medicine, Nashville, TN. He also is the director of the Center for Research and Innovation in Systems Safety (CRISS), Vanderbilt University Medical Center, Nashville, TN.*

*Brian J. Thomas, JD, is vice president – Risk Management for Preferred Physicians Medical Risk Retention Group, the nation's only medical professional liability insurance company exclusively insuring anesthesia professionals and their practices.*

*DISCLOSURE: Matthew Weinger, MD, MS, is founding shareholder and paid consultant of Ivenix Corp., an infusion pump manufacturer. He received an investigator-initiated grant from Merck to Vanderbilt University Medical Center to study clinical decision making.*



YOUR CONTRIBUTION PROVIDES FUNDING FOR IMPORTANT PROGRAMS:

Over **\$13.5 million** in research grants awarded 

**20** APSF Consensus Conferences conducted to date (no registration fees)

➤ [apsf.org](https://www.apsf.org)  
**over 1 million** visitors per year



The *APSF Newsletter* will now be translated into Mandarin, French, Japanese, Portuguese, Spanish, Russian, and Arabic.

### What do all of these individuals have in common?



Dan and Cristine Cole



Karma and Jeffrey Cooper



Burton A. Dole, Jr.



Dr. John H. and Mrs. Marsha Eichhorn



David Gaba, MD, and Deanna Mann



Drs. Alex and Carol Hannenberg



Drs. Joy L. Hawkins and Randall M. Clark



Dr. Eric and Marjorie Ho



Drs. Michael and Georgia Olympio

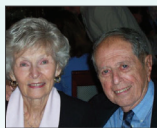

Dr. Ephraim S. (Rick) and Eileen Siker



Robert K. Stoelting, MD



Mary Ellen and Mark Warner



Matthew B. Weinger, MD, and Lisa Price



Drs. Susan and Don Watson

**Join us!**  
<https://www.apsf.org/donate/legacy-society/>



An abiding belief in safeguarding the future of anesthesiology. Established in 2019, the *APSF Legacy Society* honors those who make a gift to the foundation through their estates, wills, or trusts, thus ensuring that patient safety research and education will continue on behalf of the profession about which we are so deeply passionate.

APSF recognizes and thanks these inaugural members who have generously supported APSF through an estate or legacy gift.

For more information about planned giving, please contact Sara Moser, APSF Director of Development at: [moser@apsf.org](mailto:moser@apsf.org).